



This is a digital copy of a book that was preserved for generations on library shelves before it was carefully scanned by Google as part of a project to make the world's books discoverable online.

It has survived long enough for the copyright to expire and the book to enter the public domain. A public domain book is one that was never subject to copyright or whose legal copyright term has expired. Whether a book is in the public domain may vary country to country. Public domain books are our gateways to the past, representing a wealth of history, culture and knowledge that's often difficult to discover.

Marks, notations and other marginalia present in the original volume will appear in this file - a reminder of this book's long journey from the publisher to a library and finally to you.

### **Usage guidelines**

Google is proud to partner with libraries to digitize public domain materials and make them widely accessible. Public domain books belong to the public and we are merely their custodians. Nevertheless, this work is expensive, so in order to keep providing this resource, we have taken steps to prevent abuse by commercial parties, including placing technical restrictions on automated querying.

We also ask that you:

- + *Make non-commercial use of the files* We designed Google Book Search for use by individuals, and we request that you use these files for personal, non-commercial purposes.
- + *Refrain from automated querying* Do not send automated queries of any sort to Google's system: If you are conducting research on machine translation, optical character recognition or other areas where access to a large amount of text is helpful, please contact us. We encourage the use of public domain materials for these purposes and may be able to help.
- + *Maintain attribution* The Google "watermark" you see on each file is essential for informing people about this project and helping them find additional materials through Google Book Search. Please do not remove it.
- + *Keep it legal* Whatever your use, remember that you are responsible for ensuring that what you are doing is legal. Do not assume that just because we believe a book is in the public domain for users in the United States, that the work is also in the public domain for users in other countries. Whether a book is still in copyright varies from country to country, and we can't offer guidance on whether any specific use of any specific book is allowed. Please do not assume that a book's appearance in Google Book Search means it can be used in any manner anywhere in the world. Copyright infringement liability can be quite severe.

### **About Google Book Search**

Google's mission is to organize the world's information and to make it universally accessible and useful. Google Book Search helps readers discover the world's books while helping authors and publishers reach new audiences. You can search through the full text of this book on the web at <http://books.google.com/>

Manipulation  
of the Microscope

EDWARD BAUSCH

W. S. 1901 E

Harvard University  
Library of  
The Medical School  
and  
The School of Public Health



The Gift of





MANIPULATION  
OF THE  
MICROSCOPE

BY

EDWARD BAUSCH

---

ILLUSTRATED

---

*FOURTH EDITION*  
*TWENTIETH THOUSAND*

---

PUBLISHED BY  
PUBLICATION DEPARTMENT  
BAUSCH & LOMB OPTICAL CO.  
ROCHESTER, N. Y.

1901

HARVARD UNIVERSITY  
SCHOOL OF MEDICINE AND PUBLIC HEALTH

LIBRARY  
Gift: Estate of Dr. R. D. Young  
28 AUG 1941

3.J.1901.5

Copyright  
BAUSCH & LOMB OPTICAL CO.  
1901

PRESS OF THE  
BAUSCH & LOMB OPTICAL CO.  
ROCHESTER, N. Y.

## PREFACE TO FIRST EDITION.

It may seem to some persons an act of presumption for a maker of microscopes and microscopical accessories to enter the field of authorship and attempt to supplement the valuable labors which in recent years have made the use of the microscope an indispensable aid in the advancement of science.

To such, if any, I submit that, being a producer of microscopes and their accessories, I have had opportunity to become acquainted with the lack of general knowledge of the fundamental principles of the instrument and the best methods of technique, even among owners of microscopes. Indeed, with so many complications, with almost unlimited powers and uses of the instrument, the beginner cannot fail to feel the need of a guide and adviser.

In order to accomplish the greatest good, I have started out in this little Manual with the supposition that the purchaser, or owner, is a beginner, and absolutely ignorant of the microscope and everything which pertains to it, and therefore have attempted to convey, step by step, in as simple language as I could command, information which will, I trust, lead to ease of manipulation and give both pleasure and profit to those for whom it was specially written.

With these, its purposes and hopes, I beg for my self-imposed labor a friendly reception.

EDWARD BAUSCH.

June 1, 1885.





## PREFACE TO SECOND EDITION.

The demand for this book having considerably exceeded the expectations of its author, and the comments on its utility having been so favorable, lead to the view that it fills a gap in microscopical literature.

In preparing for a new edition an opportunity has been given for enlarging on some of the subjects and rewriting others, so as to make them conform to the changes which the last five years have brought about in the construction of apparatus.

While it may be true that many of the subjects might be treated much more extensively, the writer has purposely refrained from doing so, because he has considered it beyond the province of his intention, and because books giving more extensive information are available.

An intending purchaser of a microscope finds it more or less difficult to make a suitable selection and, while it is always best to consult an experienced microscopist, the writer has endeavored to convey information which, he hopes, will aid in this direction.

THE AUTHOR.

May, 1891.



## PREFACE TO THIRD EDITION.

The past demand for this little volume makes extended remarks superfluous, the new edition appearing as evidence that it is considered of some value.

This edition has been almost entirely rewritten to bring it in accord with the advance which has been made in the construction of microscopes and accessories and while it is not expected to be a complete guide, it is, nevertheless, hoped that it will lighten the labor of the beginner.

Since its first issue there have appeared two books covering the same purpose: "The Microscope and Microscopical Methods" by Prof. S. H. Gage of Cornell University and "Microscopical Praxis" or "Simple Methods of Ascertaining the Properties of Various Microscopical Accessories" by Dr. A. C. Stokes, both of which are heartily commended to the microscopist. Neither should be wanting in a microscopical library. The writer is also pleased to acknowledge the suggestions of an enlarged scope for this book, which he has obtained by a perusal of them, as well as from the admirable work of Dr. W. H. Dallinger in the latest issue of Carpenter, "The Microscope and its Revelations", which may be commended to those who wish to study more deeply the principles of the microscope and learn its history and development.

The writer trusts that omissions will be pardoned, as the only time which it has been possible to devote to this work has been the spare moments of a busy life, and hopes sufficient information may be obtained to give full compensation for such defects.

THE AUTHOR.

March 1, 1897.

## PREFACE TO FOURTH EDITION.

In the revision for this edition an effort has been made to reach greater conciseness in the explanations and in paragraphing the instructions in the use of various kinds of apparatus. Many of the illustrations have been replaced by new ones, and others have been added.

This book has been adopted in many schools as a text book and it is hoped that its usefulness in this direction may be extended.

THE AUTHOR.

October, 1901.



## OPTICAL PROPERTIES OF LENSES.

**Purpose of the Microscope.** The microscope is an instrument which magnifies small objects, so that we are better able to examine their structure than is possible with unassisted vision.

**Simple and Compound Microscopes.** Microscopes are divided into two classes—*simple and compound*,—the difference between the two being as follows:

The simple microscope is usually of low magnifying power and consists of one lens or a single system of lenses through which the object is viewed directly and the image is seen erect, or in its real position.

The compound microscope gives a higher magnifying power and the image formed by one system of lenses is observed through a second system of lenses, and the final magnified image appears reversed, so that what is right in the object is left in the image.

**Lenses.** As microscopes depend upon the action of lenses it seems fitting that they, as well as their action on light passing through them, should receive attention.



Every person has unquestionably observed that when a spoon is placed in a tumbler of water it is apparently bent at the surface of the water, or when looking at an object lying in the bottom of a dish, it is apparently at a different point than when viewed from the side. This is caused by the deflection or bending of the rays of light as they pass from one transparent medium into another of greater or less density and is called *refraction*. The amount of refraction increases as the difference in the density of the two media becomes greater. We also know that in viewing objects through a glass prism, they apparently lie in a direction different from their real one. The amount of this deviation depends for the one factor upon the density of the

glass composing the prism and for the other upon its shape.

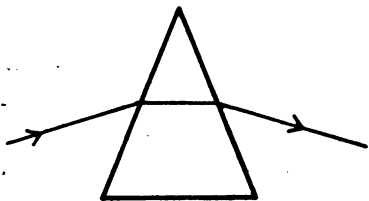

Fig. 1.

Fig. 1 represents a cross section of a prism and shows how the ray on entering at the first

surface undergoes refraction and how on emerging at the second surface a second refraction takes place. It will be noticed that the light is bent downward or *toward the base of the prism* and if the prism be imagined reversed with its base upward, the action

of the prism on the light will be the same, but the light will be bent upward, *always toward the base*.

Now a lens in either of its two principal forms is in effect a combination of two prisms. In Fig. 2, where

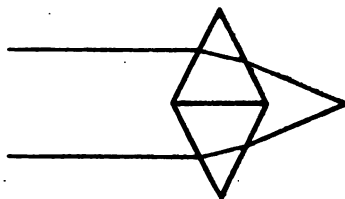

Fig. 2.

the two bases are placed together, is shown how the light is refracted toward the bases and thereby converged. In Fig. 3, where the bases are in reverse position, the action of the prisms

on the light is the same, the rays being refracted *toward the bases* thus causing them to diverge or separate.

In Fig. 4 is shown how, by increasing the number of prism faces, the form of a lens is gradually approached.

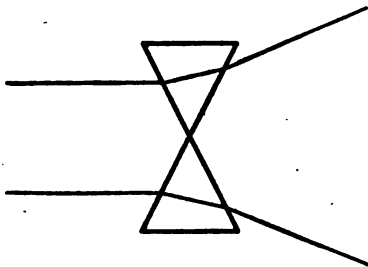

Fig. 3.

If the combinations of prisms be imagined with curved surfaces instead of flat ones, their action on light passing through them will be

precisely the same and we have the two great classes of lenses, converging or convex and diverging or concave, as shown in Fig. 5.

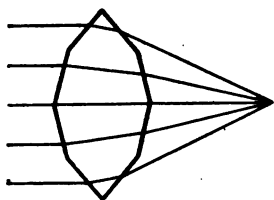

Fig. 4.



Fig. 5.



These two classes are again subdivided, Fig. 6 showing the three forms of the convex and concave

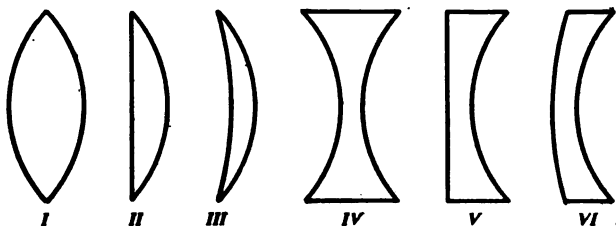

Fig. 6.

types which are, beginning at the left:

*I—double convex, II—plane convex, III—convex meniscus, IV—double concave, V—plane concave, VI—concave meniscus.*

In the convex lenses, parallel or nearly parallel rays are converged to one point as shown in Fig. 7. This point *c* is the *principal focus*, or *focal point*, and the distance from the point *b*, called the principal point, to *c* is the *focal length*.

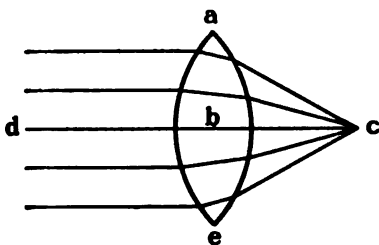

Fig. 7.

With the same lens, if a flame be placed at *c*, all the rays which strike the lens will emerge in a parallel direction on the opposite side. The straight line *d b c* which passes through the middle of the lens is called the *principal axis* and the distance *a c*, which for the sake of simplicity has been taken from the focal point as center, the *radius*.

The radius of curvature in combination with the refracting power of the glass determines the converging quality of a lens and consequently its focal length, and as the radius is lengthened the focus becomes longer. In the ordinary lenses the glass used is, with very slight variation, of the same refracting power, so that the difference in focus is dependent upon the curvature of the surfaces. If in a double convex lens the radius of each surface is one inch, the lens has a focus of one inch, and if in a plane convex lens the convex

surface has this same radius, the refracting power is one-half and the focus is twice as long, or two inches.

In a concave lens, the action of the lens is opposite; instead of converging the light toward the axis, it diverges the rays from the axis as shown in Fig. 8.

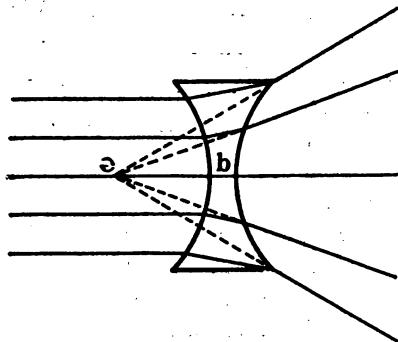

Fig. 8.

The imaginary extension of the diverging rays should meet at *e* and the distance *e b* indicates the *virtual focus*, in contradistinction to the *real focus* in the convex lens.

**To Determine the Focal Length of a Convex Lens.** The focal length of the lens may be quite accurately determined by the following methods:

*I—Hold the lens toward the sun with one hand. With the other hold a piece of paper under it. Move the paper slowly toward the lens. A large bright spot will appear, which, as the paper is brought nearer, will decrease in size but increase in intensity until it becomes quite small, and as the paper is brought still closer to the lens the image will be found to enlarge again. Return again until the spot decreases to smallest size. The distance between lens and paper is the focal length. By holding sufficiently long, the paper, especially if it be dark, will be found to burn, due to the concentration of heat rays and hence this point is called the burning point or focal point.*

*II—In a room opposite a window or at a considerable distance from a lamp, hold the end of a ruler against a white wall and place the edge of the lens against it, so that the axis of the lens will be parallel with the ruler. Move the lens slowly toward or away from the wall until a greatly reduced but bright image of either object appears sharply defined. Read off the distance between the wall and edge of lens. This is the focal length.*

In a lens of considerable thickness measure from the centre of the lens.

**Magnifying Power.** Magnifying power of a convex lens depends upon its converging power.

In Fig. 9, *a b* represents the object, *c d* the lens, *e* the pupil of the eye. By following the course of

rays from the object it will be noted how they are refracted by the lens and intercepted by the pupil of the eye. If now the lines between *c* and *d* be prolonged, they will be found to meet beyond *a b* and there form a *virtual image*. It will be well to understand at this point the difference between a real and a virtual image. The *real image* is one which can

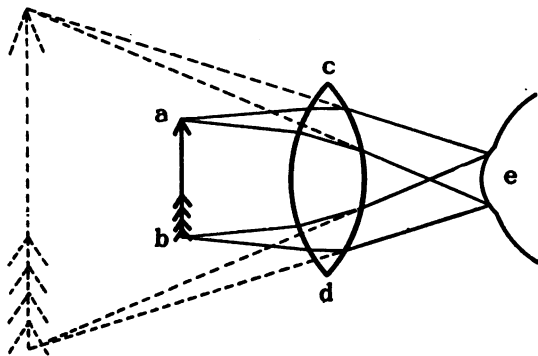

Fig. 9.

be accurately seen and projected upon a surface, as with the magic lantern, or in the photographic camera. The *virtual image* cannot be so projected, although readily seen by looking through the lens.

In a lens of less convexity or longer focus, there is less convergence of rays; the size of the virtual image is consequently reduced and thus the magnification is less.

**Spherical Aberration.** In considering the refraction of light by a lens, we have up to this point purposely avoided mentioning another quality which is incident to it. In magnifying an object with a single lens it will be noticed that the virtual image as seen through its central portion is quite clear, while that near the margin or edge is quite indistinct. This is due to *spherical aberration* and the extent of this aberration increases with the power of the lens.

It is due to the difference in refraction of those rays passing near the margin and those passing through the central portion, so that the rays, instead of combining at the focal point, come together at different intervals along the central line or principal axis.

By reference to Fig. 10 it will be seen that the outer or marginal rays are refracted at  $e$  and  $f$  so

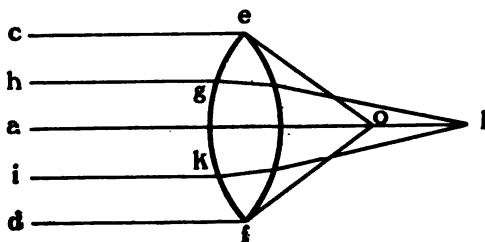

Fig. 10.

that they will combine at  $o$ , and the inner or central rays are refracted at  $g$  and  $k$  so that they will meet



at  $l$ . In the same manner will the rays which enter between  $c h$  and  $i d$  come together at intermediate points between  $o$  and  $l$ , and those of the central portion between  $h$  and  $i$  will fall beyond  $l$ . Spherical aberration increases with the decrease in the focus of a lens and in lenses of the same focus but different form, is greatest in the double convex and least in the so-called crossed lens, in which the two convex surfaces are of different radii and in the proportion of 1 to 6, *on condition*, however, that the surface of shorter radius is directed toward the object.

This latter form of magnifying lens is seldom used, as it shows the greatest amount of aberration if used in the reversed position. The most common form is the double convex with equal curvatures and when considerable magnifying power is desired, the defects of spherical aberration are partially overcome by the interposition of an opaque plate, with round opening, to shut out the marginal rays. This plate is called a *diaphragm* and when used the lens is said to be *stopped down*.

**Chromatic Aberration.** In magnifying an object with a single lens it will be noticed that it has not only the defect of spherical aberration, but that the object appears fringed with colors, predominantly violet and red, or if objects are viewed through a prism, we have not only an apparent change of position, but a decided

appearance of so-called rainbow colors. This appearance is called *chromatic aberration* and is a result of refraction. It is caused by dispersion or the *dispersive quality*, the separation of light into its primary colors, *violet, indigo, blue, green, yellow, orange and red*, in the order given.

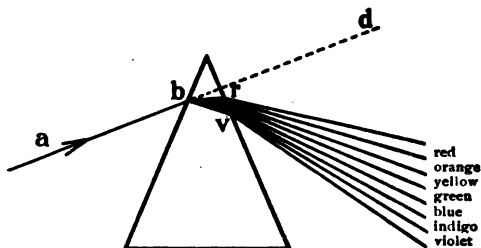

Fig. 11.

The dispersion of light by a prism is shown in Fig. 11, and it will be seen that the ray of white light *a b* on entering the prism at *b* is separated into the different colors in the order given, and that on emergence at the second surface the violet ray at *v* has undergone the greatest amount of refraction and the red ray at *r* the least. The band of colors formed is called the *spectrum*. The results of dispersion are nicely illustrated in the diamond, this having a very high degree of refracting power and is polished or cut to make a many-sided prism in which each face or

facet creates refraction with its consequent dispersion and play of colors.

With the light as refracted by a lens or prism, on its emergence the violet ray, being the more refrangible, will be principally affected and be brought to a focus within the principal focus, and the red ray will be brought to a focus beyond that of the violet.

To avoid spherical and chromatic aberrations to the greatest possible extent has been for many years the study of opticians:

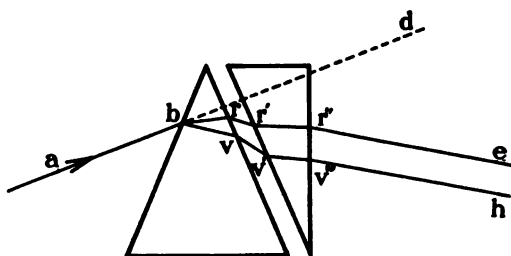
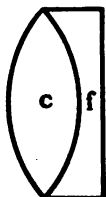

Fig. 12.

How this was successfully accomplished is explained by reference to Fig. 12 where it will be seen that the ray of white light is separated into the various colored rays, from red to violet, in passing through the first prism which is made of crown glass, and that the rays would continue to diverge in the direction  $r r'$  for the red, and  $v v'$  for the violet. If now a second prism of

suitable flint glass with about one-half the refracting angle and in reversed position is placed close to the first or crown glass prism the red ray will be refracted in the direction  $r' r''$ , and the violet in the direction  $v' v''$ , so that on emerging at  $r''$  and  $v''$  respectively, the red and blue rays will continue in a parallel course and thus be recomposed into a beam of white light, which is changed in its direction from  $a b d$  to  $r'' e$ .

Thus it is possible not only to avoid dispersion but to obtain a converging effect. If now the prisms will be imagined as a combination of lenses we have a so-called *corrected* or *achromatic combination* or *lens*.



If the chromatic and spherical aberrations are both corrected it is called *aplanatic*. The convex lens is made of *crown glass* and the concave of *flint glass*.

Fig. 13.

The corrected lens shown in Fig. 13 is an achromatic lens of the simplest form and while not absolutely corrected is generally used when the demands on it are not too great. Better correction is obtained when two or more of these lenses are used in combination and they are thus used in some of the lenses of the compound microscope. The variety of forms, due to the variety of glass from which combinations may be made, is almost infinite.

## SIMPLE MICROSCOPES.

Simple microscopes are usually termed *magnifiers* and whether consisting of one or several lenses in close contact, *always remain simple*. They are made to be held in the hand or are fixed on a *stand* or *mounting*, which is provided with adjustments for focusing, thus giving steadiness and leaving the hands free for dissecting or moving the object



Fig. 14.

during observation. Magnifiers are made in a large variety of forms, the difference appearing in their optical as well as mechanical construction. The most common are those with one or several double convex lenses mounted in hard rubber or vulcanite, nickel, aluminum, celluloid, etc., and arranged to be folded for pocket use as shown in

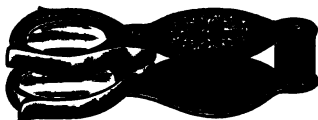

Fig. 15.

Fig. 14 and Fig. 15. Those containing several lenses are preferable, since they offer a variety of magnify-

ing powers and in combination give the greatest magnification admissible with single lenses.

**Doublet Magnifier.** This lens, Fig. 16, recently introduced, is composed of two separated plane convex lenses and, while not so compact for pocket use, eliminates some of the optical defects of the ordinary magnifiers.



Fig. 16.

**Coddington Lens.** A lens of greater efficiency than either the ordinary magnifier or the doublet magnifier is the *Coddington lens*, Fig. 17.

While this is also a single double convex lens it will be noticed that it has considerable thickness, being really the central portion of a sphere and provided with a circular incision at the middle, which is blackened and thus acts as a diaphragm, shutting out the marginal rays and correcting the spherical aberration, at the same time, however, limiting the size of field.



Fig. 17.

In selecting a Coddington, one should avoid those which are often offered as the real and which consist

of two double convex lenses, separated by a black diaphragm, giving the external appearance of a Codrington while in reality being only an inferior Doublet.

**Aplanatic Triplet.** The best type of magnifier is the *Aplanatic Triplet*, Fig. 18. It is composed of three lenses cemented together in such a manner that they are virtually one. For many years this form was,



Fig. 18.

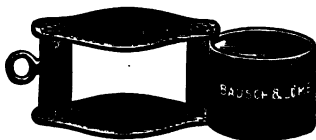

Fig. 19.

on account of cost, used only to a limited extent, but an increased demand has brought about a greatly reduced price. Its advantage lies in the fact that both the spherical and chromatic aberrations are corrected to a high degree, thus enabling the observation of minute detail and giving a *large field* which is flat to the extreme margin. It can be highly recommended to those wishing a good magnifier.

**Hastings' Aplanatic Triplet.** This form of lens, Fig. 19, has been computed by Prof. C. S. Hastings of Yale University and is a modification of the Aplanatic Triplet, giving not only the highest spherical and chro-

matic corrections, but a considerably *flatter* and *larger angular field* and *longer working distance*; that is, the distance between lens and object is greater and is an important feature in higher powers, as it admits of better illumination of the object and greater ease in working.

In all the better types of magnifiers the vulcanite mountings are discarded for those made of metal, especially German silver, although many are used of pure silver and some even of gold.

**Reading Glass.** When magnifying lenses reach a diameter of 2 inches or more they are usually termed *Reading Glasses* and are then provided with a handle. They are used to examine large objects or areas, where a low magnification is sufficient, to enlarge small printed matter, or to determine detail in engravings and photographs.

**Bruecke Lens.** This lens, named after its inventor, is designed to give a longer working distance between lens and object than can be obtained with simple lenses of the same magnifying power and to give an erect image at the same time, such qualities being manifestly desirable for dissecting and similar work.

A combination of achromatic lenses forms the image which is viewed through an achromatic con-



cave eye lens by means of which magnifications from 5 to 100 diameters are obtained. Change in magnifying power is conveniently made either by changing the object lenses or by varying the position of the eye lens. The field of this lens is necessarily small but it is the only form yet devised by which a long working distance combined with high magnifying power can be obtained.

**HOLDERS, STANDS AND DISSECTING MICROSCOPES.** There is a great variety of mechanical contrivances for holding magnifiers, to give steadiness as well as to leave the hands free for moving and working

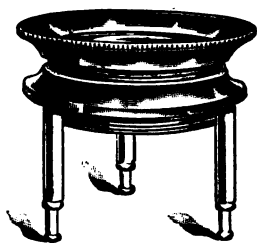

Fig. 20.

on the object and adjusting for focus. When provision is made to hold and adjust the lens the apparatus may be called a *lens holder* or *stand*, but when a platform called a *stage*, upon which the object can be placed, and a mirror for illuminating the object properly, are added, it is called a *dissecting microscope*.

There are two forms of magnifiers which contain within themselves some properties of stands. One, the *Tripod Magnifier*, Fig. 20, rests upon three legs and has a screw for adjustment of focus. Its optical parts

are two convex lenses, usually having a power of ten diameters, which are separated by a diaphragm, giving a large, fairly flat field. It is especially used in primary botanical and zoological work.

Another is the *Linen Tester*, Fig. 21. It is made in various sizes, but the ordinary form has a lens of

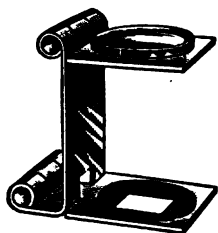

Fig. 21.

1 inch focus. It is arranged to fold into small compass for convenience in carrying, and when opened for use is placed over the object so that this comes into the square opening in the base and is then exactly in the focus of the lens. Its principal use, as its name indicates, is in the textile industries

for counting the number of threads which appear in the standard openings of  $\frac{1}{4}$  or  $\frac{1}{2}$  inch.

The simplest form of holder is a base to which is fixed a series of ball and socket joints, which offer means of adjusting the magnifier in every direction. A spring clip is provided for holding magnifiers of different sizes. The lens is focused by raising and lowering the lens clip by hand. In some of the more complex holders there is a rack and pinion for focusing the lens which adds to convenience in working.

For finer dissecting work a *stand* with firm base, stage, lens holder, and mirror, and with adjustment for

the magnifier is required. Of this type Fig. 22 represents one of the most simple and inexpensive forms;



**Fig. 22. Barnes Dissecting Microscope.**

Fig. 23 a compact form in which all the parts may be placed in the box which forms the base so that the

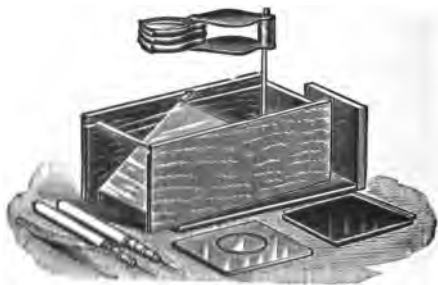

**Fig. 23.**

whole may be carried in the pocket, while Fig. 24 shows a form recommended by the highest authorities for advanced work.

**How to use Magnifiers and Dissecting Microscopes.** It is generally admitted that the intelligent use of a magnifier is a great aid in microscopical studies and while its use is a simple matter, some words of advice may be of aid in obtaining better results, or lead to doing work with more comfort. In all work, whether with simple or compound microscopes, it is a good plan to start out with the principle *not to use a greater magnifying power than is necessary to accomplish the results in view.*



Fig. 24.

*It should be made a habit at the outset to keep both eyes open.*

Keep the eye comfortably near to the upper surface of the lens, as the angular view or field is increased, there is the least spherical aberration, and the focal distance is the greatest. This can be easily tested by gradually increasing the distance between the eye and lens, when it will be found that the lens must be brought nearer to the object. In single lenses the spherical and chromatic aberrations

become more pronounced and the field smaller as the distance between eye and lens is increased.

When magnifiers are used on opaque objects—those which are not transparent and which are illuminated by reflected light not transmitted through them—a position should be chosen opposite a window or flame that the greatest amount of light will reach the object. If a hat is worn place it back on the head so that the rim will not cut off the light.

*Holding the object in one hand, take the magnifier between the thumb and forefinger of the other and place the fingers of the hand holding the lens in such a manner that they shall rest upon the other hand, thus insuring steadiness of the lens and object and adding considerably to the comfort of working.*

While it seldom occurs that magnifiers are made with other than double convex surfaces, single achromatic lenses with plane convex surfaces are sometimes used. These should be used with their convex surfaces toward each other.

*In magnifiers containing several lenses, when they are used together, the one of highest power should be nearest the object.*

When reversed the angular field is greater, but the spherical and chromatic aberrations are correspondingly greater.

In simple dissecting microscopes like the Barnes, in which the mirror is in a fixed position, the microscope should be set squarely before the source of light. Diffused day light is always preferable to any artificial illumination.



Correct manner of holding magnifier and object.

Whatever the source of light may be it is seldom too strong when viewing opaque objects; in fact the want of sufficient light is too often experienced, especially indoors. With transparent objects, however, whether viewed by looking toward the light or by means of a reflecting mirror the contrary is too often the case, so that an object is viewed in a glare of light and is liable to injuriously affect the eye.

*When the light is too strong reduce it or change the position of the body or the instrument.*

While in some classes of work it is perhaps unnecessary to have the very best magnifiers, such as the Aplanatic or Hastings' Aplanatic Triplets, the latter can always be recommended, when the means will permit, on account of the higher results and greater

degree of satisfaction and comfort derived from them.

**Caution.** Unless a microscope, whether simple or compound, is known to come from the hands of a reliable maker, any claim as to magnifying power should be accepted with reserve. In former years, when the country was overrun with cheap foreign productions, the most fanciful claims were made in this direction. Avoid strolling or street vendors who, as a rule, not only make the most ridiculous claims as to magnifying power, but charge much higher prices than the same articles can be bought for from reliable opticians and generally offer worthless articles or, at best, of doubtful value.

Some precaution should also be used in reference to quality in purchasing a magnifier. As competition causes a downward tendency in prices, it unfortunately often involves a deterioration in quality. The ordinary forms are mounted in vulcanite; black horn is often palmed off as such, but is a poor substitute as it warps and cracks. The surfaces of lenses, instead of being perfectly polished, are often scratched and unfinished, showing small pitholes or undulating surfaces. This is common among cheap Coddington lenses and naturally destroys the distinctness of the image.

**Magnifying Power.** It is evident that a lens magnifies an object equally in all directions; this is said to be in *areas*, and is the square of the *linear*, or *diameter*, so that if an object is magnified four times

in the linear, it is magnified sixteen times in area. The commonly accepted term to express magnifying power of simple as well as compound microscopes is in *diameters* (linear).

**To Determine Magnifying Power.** *For simple lenses the magnifying power may be determined by dividing ten by the focal length in inches.* Thus a single lens of 1 inch focus magnifies about ten diameters; one of 2 inch focus, about five diameters; one of  $\frac{1}{2}$  inch focus, twenty diameters, and so on. In a lens of high magnifying power, the focus is ordinarily made about twice the diameter, so that if a lens is  $\frac{1}{2}$  inch diameter its focus is about 1 inch.

While the determination of focus in single lenses gives approximate magnifying power, it will not do so in some of the forms which have been described. The following method, if carefully followed, will give very accurate results and is withal simple and interesting: Place a sheet of white paper on the table. With the source of light at the right or left hand, arrange a pile of books to such height that when the magnifier to be tested is placed upon the pile with the lens projecting toward the observer the distance between the upper surface of the lens and the paper will be exactly ten inches. The magnifier can be held in place by another book placed upon it. Place a pocket ruler between the leaves of the upper book so that when the edge is close to the magnifier the divisions on the ruler



will be exactly in focus. Place the ruler so that it will not cover much of the lens. It is immaterial what the divisions on the ruler are, whether inches or millimeters, so long as they are reasonably fine. View the divisions with the right eye and open the left eye, when it will be found that the divisions are apparently projected upon the paper. Take a pencil and outline one of the spaces upon the paper. By dividing this enlarged space by the actual number of divisions on the ruler, the exact magnifying power will be determined. Thus, if it is found that the one space on the paper contains five spaces on the ruler, the magnifying power is five, and the focus of the lens 2 inches; or if ten spaces, it is ten, with a focus of 1 inch. One or several lenses in conjunction may be examined in this way. Some difficulty may and probably will be experienced in seeing the divisions on the ruler and on the paper at the same time, but this will be overcome with a little practice. Indeed, it is well to point out at this stage that both eyes should be kept open in viewing objects through simple as well as compound microscopes, as continued work can be done with infinitely more comfort and, while at first some difficulty may be experienced, it will be found that after a little earnest effort, both eyes unconsciously remain open and the prominence with which objects appear to the unoccupied eye diminishes as the mind becomes intent upon the object it is viewing.

## THE COMPOUND MICROSCOPE.

As has been stated a *magnified image* is observed in the Compound Microscope. Any two lenses of suitable focus, placed sufficiently far apart, will attain this object, and this was for years the method of construction.

In any microscope, whether simple or compound, the difficulty of holding it or the object steady during observation increases with the increase in magnifying power, and in the compound form with only a moderately high power it is utterly impossible to retain sufficient steadiness to make any reliable observation. Mechanical contrivances therefore are a necessity and were applied in the very earliest constructions of the microscope. Even when such a luxury as an achromatic lens was unknown they were all made to embody the following essential parts:

A platform or stage for holding the object.

A means of adjustment for properly focusing the lenses on the object.

Provisions for suitably illuminating the object.

From what may be called a crude attainment of these three purposes, the construction gradually became more complex. Many additions have been made which have proven useful and have remained, while others have been discarded. As the first microscope was constructed in 1590, it has required nearly three centuries to bring the instrument up to its present general form, and it is interesting to note that many improvements which have been introduced within the last forty or fifty years have been used and lost sight of within this time.

While certain parts are necessary to make up a modern instrument, no one design of construction is followed. The forms are innumerable, each maker following his own inclination in variety, design, number of parts, and material. For the latter, brass predominates, although bronze and iron are used to a considerable extent. The first two metals are usually highly finished and, as they easily tarnish, are protected by lacquer, which not only is serviceable in this direction when of proper composition and rightly applied, but offers a means of ornamentation. Iron is covered with a heavy coating of japan and being dark is on this account often recommended as being agreeable for the eyes.

The entire apparatus, *including the optical parts*, is called a *microscope*, whereas, without them, it is termed a *stand*.

The microscope is called by some a "machine", but we earnestly protest against this harsh term being applied to an instrument of such precision.

As it is necessary for the student to become conversant with the names of the various parts and to understand their use, we give an illustration, Fig. 25, with the parts lettered for better identification, and append a list giving their names. We recommend that they be impressed upon the memory, as they are the basis of microscopical language.

**A. Base**, the foundation of the instrument. It usually rests upon three points (or should do so) and is of such weight that it keeps the instrument firm when it is in an upright *or inclined* position. The two principal forms are the horseshoe and tripod.

**B. Pillar**, the vertical column which is fastened to the base and carries in its upper end the joint or axis which is provided for inclining the instrument. It generally consists of one piece, either round or square, but, in larger instruments, is often made in two columns.

**C. Arm**, supports all the upper working parts of the instrument and carries the adjustments for focus.

**D. Body**, the tube portion to which the optical parts are attached.

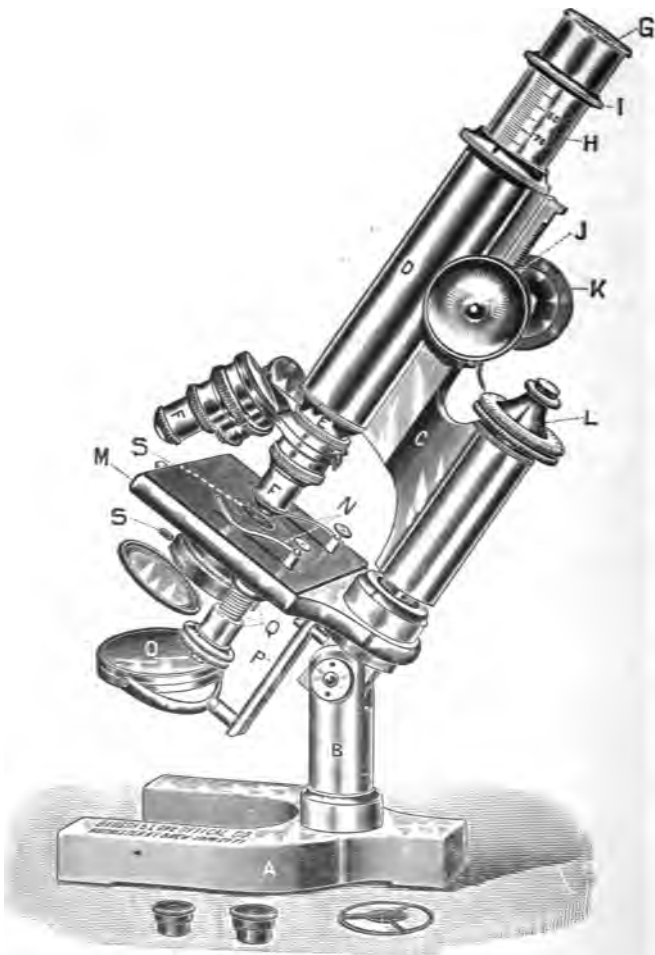

Fig. 25.

**E. Nose-Piece**, an extra piece which is attached to the lower part of the tube to hold the objective.

**Society Screw**, a standard screw which is cut into the nose-piece and is called so from the fact that it was first recommended by the Royal Microscopical Society of London. It is also called the *universal screw* and is in general use in this country.

**F. Objective**, contains the object lenses, is screwed into the nose-piece and is called so because it is nearest the object. It is the most important of the two optical parts (of the microscope proper) and upon its perfection the distinctness of the image and therefore the value of the instrument almost entirely depends.

**G. Eyepiece or Ocular**, the remaining optical part, and called so because it is nearest the eye. It magnifies the image given by the objective. This and the objective will be fully treated later on.

**H. Draw-Tube**, the inner tube of the body which moves in the outer sheath and which receives the eyepiece. It permits adjustment for different tube lengths and variations in magnifying power.

**I. Collar**, a ring which is attached to the draw-tube and is usually provided with a *milled or knurled edge*.

**J. Coarse Adjustment**, a mechanism for moving the body quickly back and forth for adjusting the focus approximately. It consists of a slide attached to the body, and a straight *rack*, the former being fitted to a recess, the latter engaging the teeth of a *pinion* which is stationary in the arm. In instruments of very simple form the coarse adjustment is obtained by fitting the body in an outer stationary sheath.

**K. Milled-Heads**, the large buttons attached to the shanks of the pinion, which is revolved by means of them. They are usually large to give sensitiveness to the movement, and should be placed wide apart so that the fingers may be entirely free from the body.

**L. Micrometer Screw**, a fine screw provided with milled head. It acts upon the body either directly or by levers. It has a slow and delicate movement and provides the fine adjustment. This as well as the coarse adjustment should be extremely sensitive and should not have the least side or lateral motion. The fact that either of them has it, is evidence of poor workmanship.

**M. Stage**, consists of a strong metal plate, placed at a right angle to the body, and provided with an opening for the passage of light from below. The object is placed upon it for examination.

**Centering Screws** are provided in some stands for moving the stage in different directions to bring the center of its revolving motion in the center of the field. In a limited sense they offer means of mechanical movement for the object.

**N. Clips**, two springs attached to the upper surface of the stage and used to hold the object in position.

**O. Mirror**, used for reflecting and condensing light upon the object. As a rule there are two mirrors, one plane and the other concave. The former gives a comparatively weak light, while the latter concentrates it and gives more intensity.

**P. Mirror Bar**, carries the mirror and is pivoted in order to illuminate the object from different directions.

**Q. Substage**, a tube or attachment below the stage, of standard size, to receive various accessories which may be required. It is sometimes immovably fixed to the stage but in the best instruments is provided with an adjustment to vary its distance from the object.

**S. Diaphragm**, a provision for increasing or decreasing the amount of light which illuminates the object.



**Optical Axis**, an imaginary line which passes from the center of the eyepiece through the centers of the body, objective, stage and substage to the mirror. Whatever lies in it is said to be *centered*.

**Object**, that which is examined.

**Slide or Slip**, a plate of glass upon which the object is placed or mounted; the prevailing standard being 3 inches long by 1 inch wide.

**Cover Glass**, a thin piece of glass cut circular or square, which is placed upon the object, either for flattening or preserving it, or both. The thickness varies from 1-50 to 1-250 inch and this variation has a very important bearing on the optical effect of the microscope.

**Classification of Microscopes.** Until recently microscopes were divided into two classes, the Jackson and the Ross models. While the latter was for many years very popular, particularly with the English makers, it has been almost entirely superseded by the Jackson form, and with good reason. In the former the means of adjustment were applied, as near as consistent with the construction, to the body tube; whereas in the Ross form they were placed at the back or more distant point in the instrument, thus increasing by means of the connecting arm the faults which might exist in the adjustment.

A form of stand which is now very popular is called the *Continental* pattern, from the fact that it was originally made on the continent of Europe, and is a combination of the Jackson and the Ross models. The coarse adjustment, when consisting of a rack and pinion, is placed close to the tube while the fine adjustment is placed in the arm.

**Tube Length.** The Continental form, Fig. 25, which is quite generally used in all countries, has a short tube from 160.0 to 170.0 mm. (6.3 to 6.7 inches) whereas in England the long tube from 216.0 to 250.0 mm. (8.5 to 10 inches) is still retained to a considerable extent. The short tube contracts the height of the instrument, this being the vital point in the construction of the Continental stand.

Until recently this subject was given little attention, each maker following a standard which he had adopted for himself. The injurious influence of this diversity was not appreciated by the public, as it was not acquainted with the products of different makers, until Prof. S. H. Gage made it the subject of a paper before the American Microscopical Society and, as a result of his inquiries, prepared the table of standards, Fig. 26, followed by the different makers.

Acting on his suggestion a committee was appointed to consider this subject, as well as that of eyepiece, objective and thickness of cover glass, to which we will

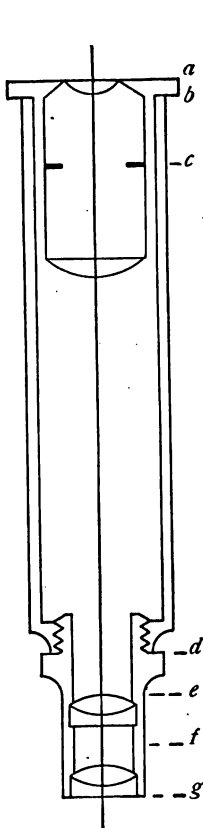

Parts included  
in Tube length  
See Diagram.

Tube-length  
in  
Millimeters.

{	a-d	Grunow, - - -	203
		E. Leitz, - - -	170
		Nachet et Fils, -	146 or 200
		Powell and Lealand, -	254
		C. Reichert, - -	160 to 180
		Spencer Lens Co., -	235 or 160
		W. Wales, - - -	254
{	b-d	Bausch & Lomb Opt. Co.,	216 or 160
		Bezu, Hauser et Cie.,	220
		Klonne und Muller, -	160-180 or 254
		W. & H. Seibert, -	190
		Swift & Son, - - -	165 to 228½
		C. Zeiss, - - -	160 or 250
{	a-g	Gundlach Optical Co.,	254
		R. Winkel, - - -	220
		Ross & Co., - - -	254
		R. & J. Beck, - - -	254
		J. Green, - - -	254
		Hartnack, - - -	160-180
		Verick, - - -	160-200
		Watson & Sons, -	160-250

Fig. 26

recur farther on, and reported in favor of the adoption of two standards for tube length, viz., short standard 160.0 mm. (6.3 inches), long standard 216 mm. (8.5 inches); that the tube length shall be considered those parts between the upper end of the tube where the ocular is inserted and the lower end of the tube where the objective is inserted. There are no optical advantages in the one or the other. The short length is almost a necessity, however, in the Continental pattern of microscopes as compactness is the special desideratum; but, while this subject will be given more extended attention and optically considered farther on, it might be stated here that when an objective, except perhaps in the very low powers, is constructed to be used with a certain length of tube, it should be used with this length only. This statement cannot be made too prominent and will bear repetition.

**Stage.** This should be of such strength that, under considerable magnification, the object may be moved in different directions without displacement of focus. This depends upon the material of which it is made, its thickness, and the strength of attachment between it and the arm. Absolute rigidity is practically impossible when considerable force is exerted, as can easily be determined in the best instruments, and it is a mistake to condemn an instrument for this cause as is sometimes done. If the object will remain in focus under a high power with a fair amount of pressure

above that which is required in moving the object about, the stability may be considered ample. In older instruments the fault often occurred of making the stage unnecessarily thick, which for present day requirements or with modern substage appliances would interfere with the accomplishment of the best results. At the present time the stages of instruments from reputable makers are of ample strength without undue thickness although in cheap foreign products this is too often not the case. It is of the greatest importance, however, that the surface of the stage should be square with the tube in all directions. Any deviation produces inferior optical results. In the better class of instruments a vulcanite plate attached to the upper part of the stage has proven very successful. The peculiar gritty feeling due to small particles of dust between the stage and slide is not so noticeable as on a metal surface, and it is not much affected by acids or alkalies and will therefore retain its neat appearance almost indefinitely.

**Revolving Stage.** While in the largest number of instruments the stage is fixed and generally square, there are others in which it is *revolving*, that is, may be revolved around the optical axis. Such a stage is an absolute necessity in the examination of crystals and rock sections, for which purpose *graduations* in degrees or fractions of degrees, by means of which the angles of the objects may be measured, are pro-

vided. It is supplied in most of the better class of instruments and is a convenience in almost all kinds of microscopical work. As a slight deviation of the center of revolving motion from exact coincidence with the optical axis will cause the object to swing out of the field, *centering screws* are provided by which this error can be quickly corrected. These screws are also convenient, within narrow limits, in providing a mechanical method of moving the object in different directions over the field of view. It sometimes occurs, as the stage is revolved, that an object at the edge of the field, which is in focus, gradually becomes indistinct, showing poorest at the half revolution and as the stage is brought around to the first point again comes into focus. This may be due to poor fitting of the parts, or to the fact that the stage is not square in all directions with the body; in either case a serious defect.

**Glass Stage.** This with the slide carrier, Fig. 27, is a device for moving the object more steadily and

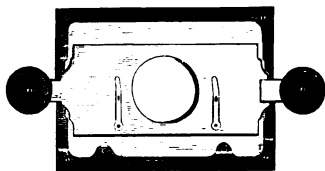

Fig. 27.

smoothly than can be done directly on the stage. It is made detachable from the microscope and consists of a glass plate, in a metal frame, upon which the slide carrier, resting on four points, moves. At each end a spring clip passes around the glass plate and

presses against its lower surface, thus offering the minimum of friction, with sufficient resistance to make an easy movement.

**Mechanical Stage.** This is a very important form in which the movements are mechanical, in two directions at right angles to each other, motion being transmitted through the milled heads by a rack and pinion or screw. It is a most useful accessory and with it work can be done systematically and rapidly with the assurance that every portion of the field has been covered and with a degree of comfort which must be experienced to be appreciated. For instance, in a bacteriological or urinary specimen, where one is searching the field for certain objects, it is the only reliable means of covering each portion of it. This stage is especially valuable for blood counting and plankton work. While not many years ago it was spurned by many scientists as a toy, it is now generally accepted as an invaluable part of a microscope. In order to be so, however, it must be of the most perfect workmanship, which is difficult to attain on account of the necessarily small parts of which it is composed and the hard usage which it must bear. The movements must be smooth and easy and on reversing the milled heads, must not show any lost motion or dead point. A great deal of attention and ingenuity has been applied in the development of the modern mechanical

stage. In its early construction it was heavily built and of a thickness which would make it unsuitable for use with modern substage accessories.

There are two different types, *fixed* and *attachable*. In the fixed, which is generally also revolving, the

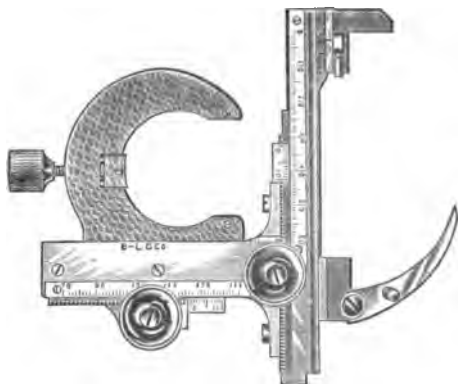

Fig. 28.

mechanical parts are attached to and form an integral part of the stage. The Attachable Stage, Fig. 28, is complete in itself, being attachable to the microscope, and may be removed at will. Both are provided with graduations, usually divisions in millimeters, in both directions by which one may read off the amount of space which is covered and locate the position of an object for future reference.



*In using the mechanical stage, it should first be determined how many spaces, or how much of one space is contained within the limits of the field; then begin at one edge of the specimen and with the lateral movement (right to left or vice versa) make it pass across the field. Move the slide forward with the vertical movement the amount of space which has been previously determined and by a return action of the lateral movement, bring it across again and thus through the entire specimen, or until the object is found.*

**Nose-Piece.** This being the lower end of the body, to which the objectives are attached, it is important in so far as it must be accurately made. As has been stated, it has the society screw. Previous to 1857 each maker followed a standard of his own and this to a great extent is still the case on the Continent. The Royal Microscopical Society, of London, appreciating the inconvenience of this diversity, recommended a standard thread of thirty-six to the inch with an external diameter of 0.8 inch, which was finally adopted in England and this country. The Society supplied to the makers a so-called standard hob or tap with which to gauge the thread. Unhappily, however, these taps have not been made to a standard, as there is a variation in those which are sent out by the Society, so that, while the public is under the impression that

there are fixed dimensions, there is on this account a diversity in the products of different makers; hence it often happens that the objectives of one maker will not fit the stands of others. The writer in 1884 read a paper on this subject before the American Microscopical Society and as a result a committee was appointed to bring about a better state of affairs. It failed, however, in obtaining the co-operation of the Royal Microscopical Society, the main reason being the expense involved, so that we must continue to suffer until some concerted action is taken by the manufacturers themselves, which we trust will not be far distant.

**Revolving Nose-Pieces.** Changing one objective for another to obtain a different power is time consum-



Fig. 29.

ing and inconvenient; besides, there is danger of dropping the objective and thus a liability of injuring it or disturbing or destroying the object. To avoid this the

*double*, the *triple*, and *quadruple nose-pieces* are offered, to the first of which two, to the next three, and to the quadruple four objectives may be attached in such a manner that, when fixed to the nose-piece of the microscope, each objective may in turn be brought into use by rotating the nose-piece. Each objective

comes to the center and will be in focus, if not exactly, at any rate very closely. This statement should perhaps be modified in so far that as the nose-piece is rotated each objective *should* be approximately in focus when in position, since objectives and nose-pieces are still supplied by makers with which this is not the case. Of all the convenient accessories these are the most useful and in most common use, the writer knowing from experience that nearly all of the instruments sold for personal use are supplied with the double nose-piece when two objectives are used, and the triple when three are taken.

**Bodies or Tubes.** These are of two kinds: *monocular*, having one body which may contain one or two draw-tubes, observations being made with one eye, and *binocular* for observation with both eyes, the two tubes being fixed together at the nose-piece and gradually separating until they reach the pupillary distance. The first is a *monocular microscope*, the second a *binocular microscope*.

While the methods for transmitting the rays from the objective to the binocular tubes vary, the construction in most common use is that introduced by Mr. Wenham.

By reference to Fig. 30 it will be seen that the rays from one-half the objective are transmitted uninterruptedly to the vertical tube, while the prism intercepts

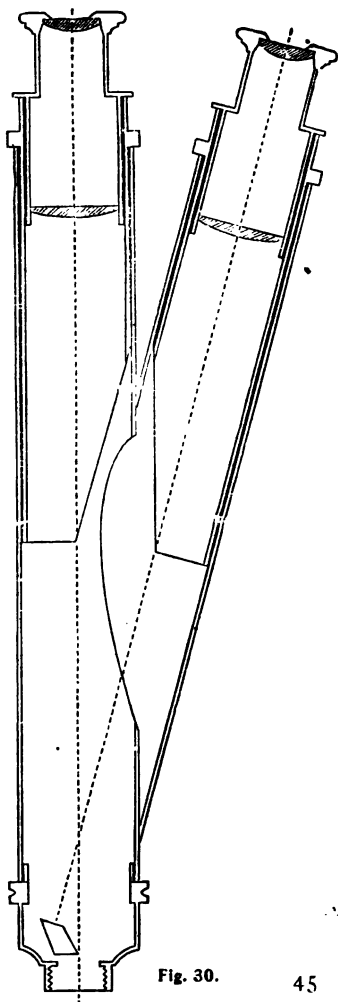

Fig. 30.

the rays from the other half and reflects them into the oblique tube. The result is an image in each eyepiece, thus giving stereoscopic vision. This gives a perception of depth, a sense of being able to look into an object, and conveys to the mind the impression of roundness or separate appreciation of the different planes of the object which it is impossible to obtain with monocular vision. Its use, however, is limited to the lower power objectives.

**Coarse Adjustment.** In providing this adjustment, two methods are followed. The most simple form is the sliding tube in which the body tube, which carries the nose-piece at the lower end and draw-

tube at the upper end, is moved up and down in an outer sheath, which is fastened to the arm. The milled ring is grasped by thumb and fore and middle fingers and pushed down and drawn up with a spiral motion. It is not to be commended except for economical reasons, as it lacks firmness, wears out quickly from the considerable friction, endangers the object and the objective from the liability to sudden or jerking motions and does not well permit the application of the double nose-piece. While a clamping ring which fastens the tube in a fixed position is provided in some instruments, especially to permit the use of double nose-piece, this again has its disadvantages and is cumbersome. Therefore it is strongly recommended not to purchase an instrument of this kind if it can be avoided.

The *rack* and *pinion* adjustment is by far preferable in every respect and has stood the test of many years, although efforts have been made to introduce other methods, all of which, however, have become obsolete. To be satisfactory and lasting, it must be exceedingly well made and it is safe to advise that any instrument with this adjustment, which does not work well at the outset, may be regarded as a poor one. In late years the pinion with spirally cut teeth and the rack with diagonal ones has come into common use and is better than the older form with straight cut teeth. In order to make the pinion operative, bearings are provided for

it in the arm and its teeth engage in the rack, which is fastened to a slide and has its bearing in the recessed vertical length of the arm, as shown in Fig. 31.

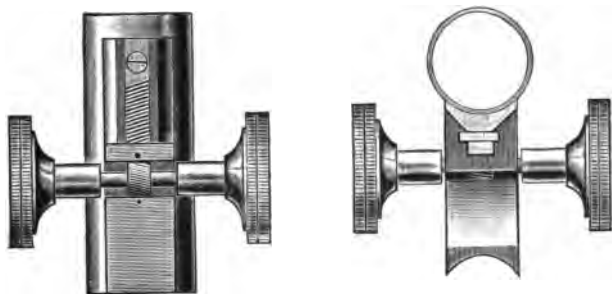

Fig. 31.

This adjustment must meet the following conditions and if it does not, the instrument may be safely condemned as faulty :

*It must work with the utmost smoothness and with not the least perceptible jar or grating.*

*It must be free from lost motion when working with the highest powers.*

*The slide must be so perfectly fitted, that it shall show no play when the tube is moderately forced from one side to the other.*

It is opportune in this connection to state that all fittings involved in the rack and pinion are necessarily

delicate and great care should be exercised in using the adjustment and keeping the parts free from dust. Lubrication should never be necessary between the teeth of the rack and pinion. When applied to the spindles of the pinion it should be only a very small quantity of the best oil, and when lubricating the sliding parts, wipe these with cambric to which a drop of oil has first been applied. A surplus amount of oil acts as a dust catcher.

**Fine Adjustment.** While this is constructed in numerous ways, in all it depends upon a screw for the propelling power. It is sometimes called the *slow motion*, as one revolution of the screw seldom gives more than 1-50 inch motion. This screw is also called the *micrometer screw*. The brass button by which it is rotated is called its *head* and, when it is provided with equal divisions upon its upper surface, it is the *graduated head*. In this case a stationary *index* is fastened to the arm.

The fine adjustment, although it should be delicate and sensitive, must, nevertheless, be rigidly constructed. Its bearings must be large and still free so as to be responsive to the movement of the screw, and these conditions must be maintained with an endless amount of use.

While the fine adjustment, even more than the stage, will show displacement with moderate magnify-

ing power by a slight pressure against the tube, it should return to its position when released.

If a new instrument does not meet the conditions here set down for testing a fine or coarse adjustment, it may be put down as of faulty construction, no matter by whom made or how well made it may appear in other respects.

A fine adjustment should fulfill the following conditions :

*The screw must work freely and smoothly, and without any side motion or play.*

*The adjustment should act promptly without the least particle of hesitation or lost motion.*

*There should not be the slightest displacement of the object in the field when the screw-head is worked back and forth.*

**Draw-Tube.** While this part of the instrument may be an advantage when judiciously used, it may have an injurious influence when abused. It will give both short and long tube standards and should be provided with a mark to indicate each length, or should have divisions by which the standard can be read off. It should not be overlooked, that when a double nose-piece is used its thickness is added to the optical tube length and the draw-tube should be shortened an equal amount. In the cheaper instruments the draw-tube



simply slides in the outer tube, but in the better instruments a special spring sleeve is provided in which the draw-tube operates. As both of these have the defect incident to the sliding tube adjustment, a cloth lining is preferable as the movement is smooth, while firm, and will remain so for an unlimited time.

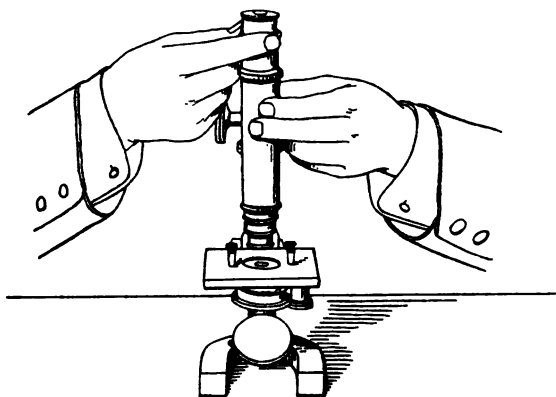

Correct position of hands to operate draw-tube.

The draw-tube may be used to vary the magnifying power, but unless used judiciously may be the cause of more harm than good. While this feature will be touched upon again in another chapter, showing the optical effect, it will suffice at the present to state that it should be used only with objectives of low power or with high powers only under well defined conditions.

The draw-tube usually has at its lower end a diaphragm to prevent reflection from the inner surfaces of the tubes, and this also sometimes has a society screw for attaching very low power objectives or accessories.

Care should be used in moving the draw-tube as a too sudden movement upward may draw the main tube with it and thus injure the rack and pinion, or downward, may force the objective onto the object or by the compression of air in the tube, may force out the eyepiece. To operate the draw-tube, *hold the main tube with one hand and with the thumb and fore-finger of the other grasp the milled edge of draw-tube and move it up or down with spiral movement.*

**Base.** A judicious form and weight of base adds greatly to the stability of the microscope and it is a too common fault that in many instruments, even from reputable makers, this essential feature is sacrificed from wrong motives of economy, portability or compactness. While it can hardly be expected that when the arm is inclined to the horizontal position the microscope shall be stable, as it is never used in this position except for photography, and must then be clamped to the table, it is but reasonable to demand that when the instrument is upright or slightly inclined under ordinary manipulative operations, it should not be required that the base be held with one hand while the other makes the adjustments. We can imagine

nothing more aggravating than a lack of stability. A considerable weight directly under the pillar is of little value, and a great expansion of the resting points with extreme thinness is little better. There should be a combination of both qualities and if suitable proportions are not maintained, an excess can hardly be called a fault, whereas too little would certainly be.

**Joint for Inclination.** This should work smoothly but firmly, and the arm should remain in any position in which it is placed. If it has a gritty sensation, the two parts are liable to "eat" and finally reach a point where they cannot be moved.

Besides the above qualification a good joint should work without the slightest back-lash when the arm is worked quickly back and forth through small arc.

When the arm comes against the stop for upright position it should not lean forward.

**Mirror and Mirror-Bar.** The proper illumination of an object is an important feature and although there are numerous accessories for properly accomplishing this, the mirrors alone are effective agents when properly constructed and applied, particularly when no high magnification is used. The plane mirror is generally used with very low powers and reflects light in about its original intensity. The concave mirror, however, is intended to concentrate the light so that all the rays which strike its surface are reflected and

come together at some point above, and the rays from the surface being contained within a comparatively small space, cause an increased intensity. This point is called the *focal point* and usually coincides with the opening of the stage when parallel rays such as from the sky are used. When the light comes from a source considerably nearer to the mirror, as from a lamp, and the rays are diverging, the focal distance becomes considerably longer. Some of the intensity is lost in consequence as well as the degree of convergence. For this reason some mirror-bars are so arranged that the distance of the mirror from the stage may be varied to accommodate the variation in the location of the source of light. While this is of considerable aid, there is in some instruments not sufficient room for a complete accommodation, with the result that, under certain conditions, the utmost effectiveness of the microscope is not obtained.

**Substage Diaphragm.** This is provided for regulating the amount of light. While it should be possible to use the mirror at its utmost capacity, it very often occurs that for certain investigations a profusion of light is more harmful than otherwise. When there is too much light objects are said to be drowned in it, and this often makes it impossible to determine structure. An intelligent use of the diaphragm is of great service.

The *revolving diaphragm* is the most simple and consists of a black disk which rotates on a pivot and

is perforated with a series of openings of different sizes, each of which may be brought into the optical axis.

Besides this there are other forms which may be said to be better—for instance the so-called *cap diaphragms*, which require a separate piece for each aperture and which are held by a special substage receiver. There are usually three cap diaphragms, each one having an aperture of different size, and when attached are located below and near the object. While the results obtained are much better than with a revolving diaphragm, a change of diaphragm is inconvenient as it involves the removal of the slide from the stage or the receiver from below the stage. An improved form has of late years been applied to the better instruments in the *iris diaphragm*, which consists of a series of thin overlapping blades placed around a central opening the size of which may be varied by means of a lever or milled edge operating the blades. Besides the possibilities of varying the size of the aperture there should be an adjustment for changing the distance from the object. The distance of the diaphragm from the object is one of considerable importance. The best position is just below the surface of the stage, but as this is not always possible, it should be as near as conditions will permit. Very recently it has been possible so to construct the iris diaphragm, that it passes up through the opening of the stage and may thus be brought very close to the object.

## OBJECTIVES AND EYEPIECES.

In taking up this subject we would say at the outset that it is fraught with difficulties, as almost all of the features are based on scientific facts which can be best explained by mathematical formulæ, but as it is our purpose to give intelligible explanations to those who may not be conversant with algebraic expressions, many of the statements and descriptions will appear rather dogmatic. We can but advise those who wish to study the subject further, to consult such books as contain more explicit information.

For the purpose of simplicity the compound microscope has up to this time been spoken of as being composed of two lenses, the lower of which magnifies the object and the upper magnifies the image formed by the lower lens. While this expresses the principle, as a matter of fact the microscope is never so constructed as the defects of chromatic and spherical aberrations would be more pronounced than in the simple microscope, even to such an extent as to nullify the benefit which might be derived from the increased magnifying power alone. In fact, magnifying power in itself is of very little value without the attributes

obtained from the chromatic and spherical corrections. The objective as well as the eyepiece is always composed of a series of lenses, the purpose of which will be explained as we proceed. The advent of achromatic lenses was the first decisive step in advance and has been the foundation of all latter improvements and the high standard of the best production of the present day.

It is a matter of pride to Americans to note that two of our countrymen, now deceased, were influential in furthering the progress to a considerable extent, and their memories should always be honored by the microscopical world. They should be remembered with feelings of gratitude, particularly as the compensation for their efforts was extremely limited. The pioneer in microscopical optics in this country was Charles E. Spencer who was followed by Robert B. Tolles, and while both men did a great amount of original advanced work, it is the latter, particularly, who, by his wonderful achievements, created a great discussion in European circles, by obtaining results which for a long time it was claimed could not be accomplished.

Of inestimable value to the scientific world have been the labors of that most capable and genial gentleman, Prof. E. Abbe, of Jena, to whom, while best known to the general microscopist for some of his more insignificant improvements, such as the Abbe condenser, camera lucida, apertometer and apochromatic

objectives, we are much more indebted for his profound disclosure of the principles of microscopical optics, as well as to the combined efforts of himself and Dr. Schott for their labors in the art of glass making and to the large variety of glass which they have placed at the disposal of opticians, who by this means have been able to accomplish much higher results than would otherwise have been the case. All of the ordinary kinds of glass, faultless as they may appear, are entirely unsuitable for use in the production of the higher grade of optical instruments. The production of optical glass for this use is fraught with many difficulties. It must be absolutely homogeneous, free from impurities and unchangeable under varying climatic conditions. The mere fact of the existence of air bubbles, while undesirable, is not necessarily a defect, as it has been found impossible to produce certain kinds of glass without them.

The amount of injury due to air bubbles is in the loss of light, and as microscope lenses are small the percentage of this loss may be considerable, therefore bubbles are carefully avoided.

In this connection it is opportune to state that the production of this glass, generally termed *Jena glass*, has been taken advantage of by unscrupulous parties in creating the impression that the bare fact of using this glass gives in itself much better results. Such is not at all the case. The merit of the production con-



sists mainly in the large variety of glass with different ratios of refractive index and dispersive power, and its effectiveness in lens making depends entirely on its intelligent use by the optician.

As defects in the objective have already been specially mentioned, it will at this point be well to state that while an achromatic lens is unnecessary in the eyepiece, a supplementary lens below and near the upper lens has been found beneficial in so affecting the image, by collecting the rays, that it can be viewed at one glance and without spherical or chromatic aberration. For this reason the lower lens is called the *field* or *collective lens*, and the upper lens the *eye lens*. These lenses are mounted in a tube with fixed relations, and are then called the *eyepiece* or *ocular*. In the diagram, Fig. 32, the course of rays from the object through the objective and eyepiece is shown.  $g h$  represents the objective,  $i l$  the field lens and  $o p$  the eye lens of the eyepiece. As the rays from the object pass through the objective they are seen to cross before reaching the field lens, are converged as they pass through, and further converged by the eye lens  $o p$ . At the point  $c d$  they form a real image of the object, which can readily be seen by placing a ground glass or piece of oiled paper at this point. It is an interesting experiment and one which we recommend trying. The eye lens enlarges this image and forms a greatly magnified virtual image at  $e f$ . From this diagram

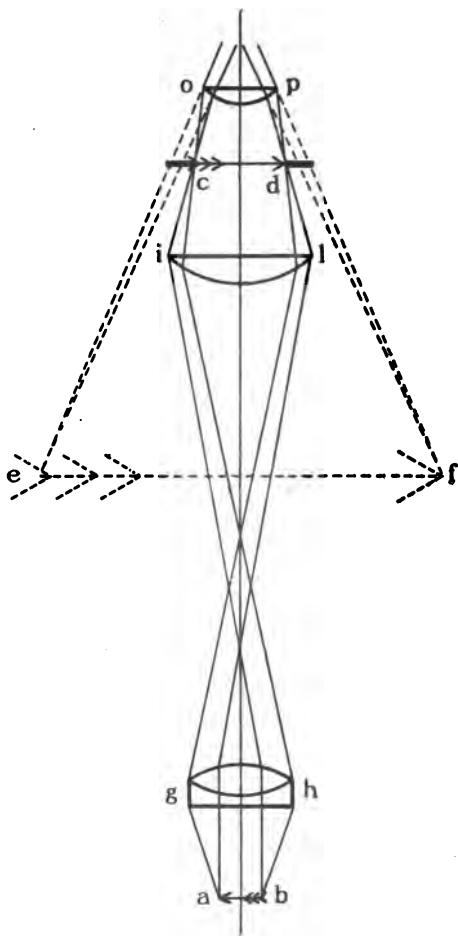

Fig. 32.

several changes with consequent results can be noted :

*If the objective is of shorter focal length, a larger real image is formed at c d.*

*If the distance between objective and eyepiece is increased, a larger real image is formed at c d.*

*If the eyepiece is of higher power, a larger virtual image is formed at e f.*

In the same manner a reduced magnifying power may be obtained by reversing these conditions.

As has already been stated, a 1 inch lens with a distance of ten inches between it and the image gives a power of ten diameters, and the eyepiece multiplies the virtual image by the extent of its power. From this it can be easily computed that with a 1 inch objective used with a tube length of ten inches and 1 inch eyepiece, a magnifying power of  $10 \times 10 = 100$  will be obtained ; or the same combination with a tube length of five inches will give one-half this power or fifty.

**Objectives** are divided into two classes, *dry* and *immersion*. In the dry objectives there is no intervening medium other than air between the lowest lens surface of the objective and the upper surface of the cover glass. In the immersion objective a liquid fills this space. From this fact it is easily seen that liquid can only be used with objectives which are quite close to the cover and therefore short focus or high power, and so, on the other hand, objectives of long focus or low

power can not be immersion. The purpose of immersion is to obtain higher optical results; is in fact a necessary condition, and an objective which is constructed as a dry one cannot be used as an immersion, and vice versa. Although there have been objectives constructed which can be used both as immersion and dry, they have gone into disuse as they must suffer when used in one or the other direction or in both.

Water was for many years used as immersion fluid, but specially prepared cedar oil was found to give better results and has almost entirely taken its place. The refractive and dispersive properties of cedar oil are almost identical with those of crown glass, and as cover glass has very nearly the same properties as crown glass, the term *homogeneous immersion fluid* is often applied to the oil, but for brevity, objectives which are constructed to be used with it are called *oil immersion*.

**Tube Length.** Objectives are constructed and their aberrations corrected for the length of tube with which they are to be used, and as has been shown in a previous chapter there are now two generally accepted standards. They are corrected for either the long or short tube and specially marked by progressive firms, and it is hoped that in time this will become a universal custom. When an objective is not marked the purchaser should require to know the tube length with which it is to be used.

### **Nomenclature, or Rating of Objectives.**

While for many years objectives were marked arbitrarily by makers and differently by each maker to designate the power, it is now customary to mark objectives so that the figures shall indicate the true optical value—on the continent of Europe in millimeters and in England and this country in inches. Objectives are rated according to their equivalent focus. *The equivalent focus of a series or combination of lenses is the same as the focus of a single lens having the same magnifying power as the series or combination. This is also true of eyepieces.* So, if two combinations equal in magnifying power a single lens of 1 inch focus they are marked 1 inch or 25.4 mm., or if a collection of four lenses is equal to a lens of 1-12 inch focus it is marked 1-12 inch, or 2 mm. Magnifying power increases in proportion to the decrease in focal length, so that a 1-12 inch objective, for instance, will give a real image twelve times larger than a 1 inch or, with a tube length of ten inches, a real magnification of 120 diameters.

**Powers.** According to their magnifying power, objectives are called low, medium, or high power and are classified by Carpenter as follows:

Low powers, 3 inch, 2 inch, 1 1-2 inch, 1 inch, 3-4 inch, 2-3 inch.

Medium powers, 1-2 inch, 4-10 inch, 1-4 inch, 1-5 inch.

High powers, 1-6 inch, 1-8 inch, 1-10 inch, 1-12 inch, 1-16 inch, 1-20 inch, 1-25 inch.

It might be stated that such powers as 1-20 and 1-25 inch are very rarely constructed at the present time and that the 1-16 inch may be considered the maximum, although seldom used. The 1-12 inch is the highest which is ordinarily used and will give all the optical advantages, while the higher powers involve so many mechanical difficulties as to increase the cost of production very considerably and as a rule rather detract from than add to the optical qualities.

While the above list of objectives comprises the variety of powers generally offered by makers, experience in the different courses of study has shown that certain objectives, and these generally in sets, are most suitable. Thus with the short tube the 2-3 is generally used for a low power, with the 1-6 and less frequently the 1-8 for a medium, and the 1-12 oil immersion for a high power. With the long tube the 3-4 and 1-5 are usually selected with the 1-12 for a high power. When the work requires low and medium powers only, the 1 1-2 and 1-2 are preferable. Of the low powers the 2, 1 1-2 or 1 inch are used. The 3 inch and lower powers are rarely required, except in photography, as the magnifying power is not much greater than that obtained by a good pocket magnifier.

**Special Objectives.** While objectives are divided into two classes, and although there are objectives, distinguished by specific names, of more complicated construction and greater capacity than those generally employed, there are other objectives, designed for special purposes, which are not suitable for ordinary investigations. An exception may be made in the so-called *variable objective*, a low power objective in which a variation in power is possible by varying the distance of the lenses by mechanical means.

**Illuminating Objectives.** These are absolutely necessary in metallurgical investigations and for examining rulings on metallic surfaces. The powers used range between 1 1-2 and 1-2 inch. A rectangular prism is fixed back of the front lens with the diagonal surface over and covering one-half of its opening. The light passes into the prism from the side of the microscope and is deflected by the diagonal surface of the prism through the front lens, which, acting as a condenser, concentrates the light on the surface of the object. The remaining one-half of the objective serves in the usual way to form the image. Satisfactory as these objectives are, they are almost useless on ordinary opaque objects on account of the reflections due to the prism.

**Photographic Microscope Objectives.** The regular objectives, especially low and medium powers, are not suited for photographic purposes on account of

lack of coincidence of the visual and chemical rays on the photographic plate; while an image may be sharply defined when viewed by the eye, that made on the plate will be indistinct. For very low powers standard photographic lenses of short focus may be used, but the microscope objective requires its chromatic corrections changed while retaining the focus, which very much detracts from its usefulness for regular microscopical work.

While the regular medium powers give fair results, they, as well as the low powers, should be adapted to these changed conditions to give the best results and particularly with a view to obtaining a greater amount of illumination.

**Projection Objectives.** These objectives are used to throw an enlarged image of an object on a white screen or wall fifteen feet or more from the apparatus.

**Systems.** An objective is said to consist of systems which may vary in number from one to four or five. Two systems are generally used in low power objectives, three and sometimes four in the medium powers, and four or five in the high powers. They are the individual portions consisting of one, two or three lenses. When a system is composed of more than one lens, the lenses are cemented together by



means of a transparent (colorless) cement in such a perfect manner that to the unpracticed eye they appear as one piece of glass. An achromatic objective may consist of a simple system having two or three lenses, or it may have two, three or four and even five systems

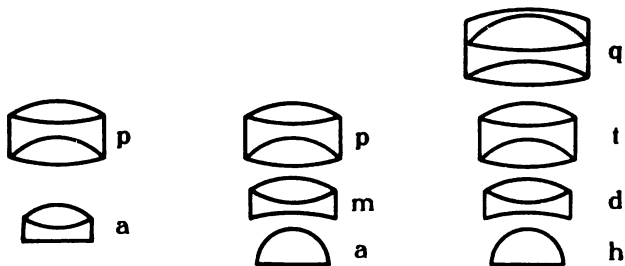

Fig. 33.

with as many as eight or ten lenses in all. The systems are called in their order: *anterior or front, middle, and posterior*. When a system consists of two lenses it is called a *doublet*, when of three lenses, a *triplet*.

Thus in Fig. 33, *a* is the anterior, *m* the middle, and *p* the posterior system: thus also, *h* is a single, *d* a double, *t* a triple, and *q* a quadruple system.

While all the work connected with the microscope must be extremely accurate, that involved in the production of an objective is of the highest degree of accuracy; in fact there is no production of the human hand which

is more delicate and one which must be so faultless. It will be noticed from the diagram that objectives of different power are different in construction and this is also true of objectives of the same power but different in efficiency. Objective makers follow different lines to obtain results, and as a large variety of glass is now offered from which to select, widely different constructions follow, which in objectives of the same class from reputable makers are very similar in efficiency.

The optical glass used must be free from defects and must be absolutely permanent under all climatic conditions. This glass comes in thick plates from the maker and is sawed into slabs of suitable thickness from which are cut pieces of the requisite size for lenses. These are then cut into lens form and the various processes of grinding, polishing, and edging follow. The control of work in these various steps must be absolute. There must be no pit holes or scratches, no variation in thickness or diameter, and the surfaces must be so perfect that all mechanical means of measurement fail and recourse must be had to highly sensitive optical tests to determine errors. The difficulties increase with the increase in the power, as all defects are magnified to the extent of the magnifying power of the microscope, and furthermore the difficulties of handling and manipulating the lenses become more serious as the lenses become smaller. The lenses are then mated and cemented, set and fixed

in suitably recessed brass mountings, carefully maintaining distances and exact coincidence with the optical axis. No matter how perfect lenses may be up to this point, negligence in mounting will make them utterly useless. Especially difficult is the setting of the minute front lenses of the medium and high powers, the latter being smaller than an ordinary pin head. The amount of metal which fixes them in position is necessarily very small, and the mounting thin, and although they are firmly set they are extremely sensitive to any blow or unusual pressure. The greatest care must also be used in cementing lenses together, as the cement between them is an immeasurably thin film, and if there is any variation in radii of the two surfaces or in their spheroidity, the cement will either fail to fill out the gap or will be under a strain which will destroy their usefulness. After all these processes the objective must undergo a critical test under the microscope for defects and if it fails in any one direction it must undergo correction. On account of the many processes and the several directions in which faults may exist this is often very difficult. It sometimes happens that one or another piece of glass possesses faults which were not previously recognizable, or that there are slight variations in the refractive power of one or another kind of glass, either of which may be fatal to good results; at any rate, whatever faults may exist, they must be entirely eliminated; the final result must

be an objective fully up to the standard previously established by the maker, and in all objectives of the same class there must be no noticeable variation.

The foregoing is given to emphasize the fact that all objectives, particularly the higher powers, are unusually accurate and delicate productions, and that unusual care should be observed in their use to retain their efficiency. This too often is not the case. There is no reason why under ordinary conditions an objective should not last a life time with daily use. Ordinary care and cleanliness will accomplish this. Nevertheless, to be more specific, observation of the following simple rules may be of aid :

*Do not allow an objective to drop.*

*Do not allow the front of the objective to come in contact with the cover glass.*

*Do not separate its systems.*

*Remove dust occasionally from the front and rear surfaces with clean camel's hair brush.*

*After using an oil immersion objective invariably remove the fluid with a soft piece of linen.*

*Never allow immersion contact with cover over ten hours.*

*Use no alcohol.*

The various features which must be considered as determining the quality of an objective are :

*Angular Aperture,*  
*Achromatism,*  
*Resolving Power,*  
*Flatness of Field,*  
*Penetration,*  
*Working Distance,*  
*Magnifying Power.*

Although these attributes may be considered separately, some of them go hand in hand. The presence or extent of one necessarily involves or precludes another.

**Angular Aperture.** The angle which the most extreme rays transmitted through the objective make at the point of focus is called the *angular aperture*, or,

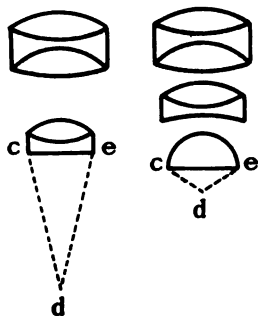
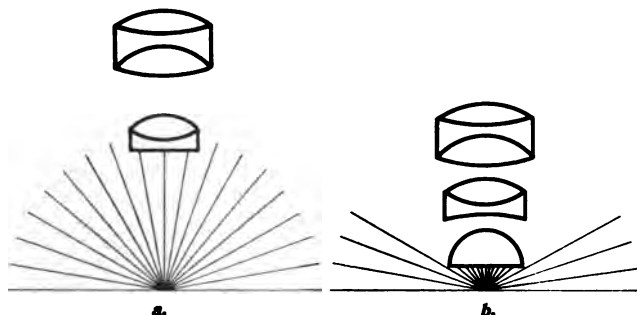

Fig. 34.

in short, the *angle* of the objective, the extent of which is expressed in degrees, and of all the qualities in an ideal objective, this is the most important. Thus in Fig. 34, *d* is considered the point of focus, and *c d e* the angular aperture. However, the above definition has its limitations. While in objectives of proper

construction it holds true, there are many in which it is not the case. For instance, an objective may be so constructed that it may transmit a considerable number of rays in excess of those which combine to form an image and it is evident that as they do not aid in forming an image, they serve no purpose and therefore have no value in the consideration of angular aperture.

Objectives of the same power are made of varying degrees of angular aperture, while others differing in power may have the same angle.



Diagrammatic representation of light transmitted by objectives of low (*a*) and high (*b*) angular aperture.

White light is radiated by objects equally in all directions, but only those rays from one-half or up to 180 degrees of the object need be considered. It is evident that the more rays which can be collected to form an image, the more distinct will it become, thus making it possible to see more detail. If of two objec-

tives one receives on its front surface and transmits a larger number of rays than another of equal magnifying power, we have a case where power would indicate that we should see equally well, but we will find that there is a difference, due to the amount of angular aperture, in favor of the wider angle. Or, in the case of two objectives in which one has one-half the power of the other, but which transmits the same amount of rays, it would appear that if the power alone were to indicate the visibility of the object, the higher one should show more detail, whereas in reality both show equally well. The practical value of this fact is most apparent near the limit of the resolving power of microscope objectives.

**Aperture.** Without the defining word 'angular,' aperture indicates a very important feature in an objective and designates the diameter of the beam or pencil of light which passes out through the rear lens of an objective, or in other words, is the effective diameter of the rear lens.

The word 'aperture' has been used, especially in England, to designate the angular aperture. This has created confusion and if an abbreviation be used the word *angle* is far more suitable, as Dallinger says in Carpenter's, "The Microscope and its Revelations," "We would, nevertheless, remark that visibility of detail in, for example, the moon depends on the aperture of

the telescope; of course what is known as its 'aperture' is simply estimated by the diameter of the object glass. The definition of 'aperture' in its legitimate sense of 'opening' is shown by Abbe to be obtained when we compare the diameter of the pencil *emergent* from the objective with the focal length of that objective."

"Thus we see that, just as in the telescope, the absolute diameter of the object glass defines the aperture, so in the microscope, the ratio between the utilized diameter of the back lens and the focal length of the objective defines its aperture. This definition is clearly a definition of aperture in its primary and only legitimate meaning of an opening, that is, the capacity of the objective for admitting rays from the object and transmitting them to the image."

"Hence 'aperture' means the greater or less capacity of objectives for gathering in rays from luminous objects."

Many objectives are made in which the rear lens is larger in diameter than the beam of rays which, coming from an object, can be transmitted through it. This, while not particularly detrimental, has no value and perhaps leads to a wrong conclusion in reference to angular aperture, when this is measured, as the excess of image forming rays, called stray rays, may indicate a greater angle and resolving power than the objective really possesses.



**Cover Glass.** At this point we must introduce another feature which has not yet been considered but which has an important bearing in the description of angular aperture. As has been shown, in describing the principles of refraction, rays which pass from air into glass, are bent out of their course or refracted. The cover glass is, as its name implies, a piece of glass to cover the object; but its purpose is really more to protect and preserve the object, or with soft or limpid objects to flatten them out, and to obtain by means of the upper surface of the cover an optically plane surface. Although extremely thin, it has a very pronounced influence on the optical performance of an objective and this influence increases as the magnifying power of the objective increases.

For the purpose of illustration, we will imagine a cover glass of considerable thickness, Fig. 35, in which  $o$

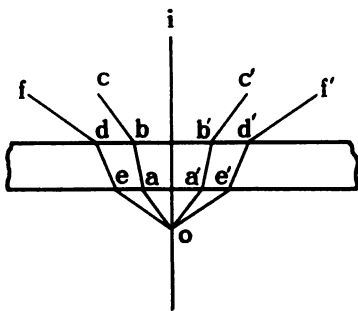

Fig. 35.

$o$  represents the source of light, or in this case the object. As  $o a$  and  $o a'$  enter at the lower surface of the cover glass they are refracted toward the axis  $o i$  and on emerging at the upper surface of the cover glass are again

refracted away from the axis in the directions  $b\ c$  and  $b'\ c'$ , which are the original directions of the rays. The same action will take place with the extreme rays  $o\ e$  and  $o\ e'$ , which will emerge as shown at  $d\ f$  and  $d'\ f'$ . If the front lens of an objective is brought close to the cover glass we can study its influence and for this purpose will use the simple but intelligible illustrations of Prof. Gage, Fig. 36.

I shows a dry objective in which the intervening medium between the top of the cover glass and the front of the objective is air.

II is a water immersion objective in which this space is filled with water.

III is an oil or homogeneous immersion objective in which the space is filled with oil of cedar.

From what has been said in regard to the laws of refraction we know that as the medium becomes more dense the refraction becomes greater and for the same reason it is clear that as the difference in density between the two media becomes less the refraction is proportionately less. As water has a greater density than air, but less than glass, refraction between these two media is less than between air and glass. As the oil of cedar has the same density as glass, the oil and glass are virtually a homogeneous mass and no refraction between these two media takes place.

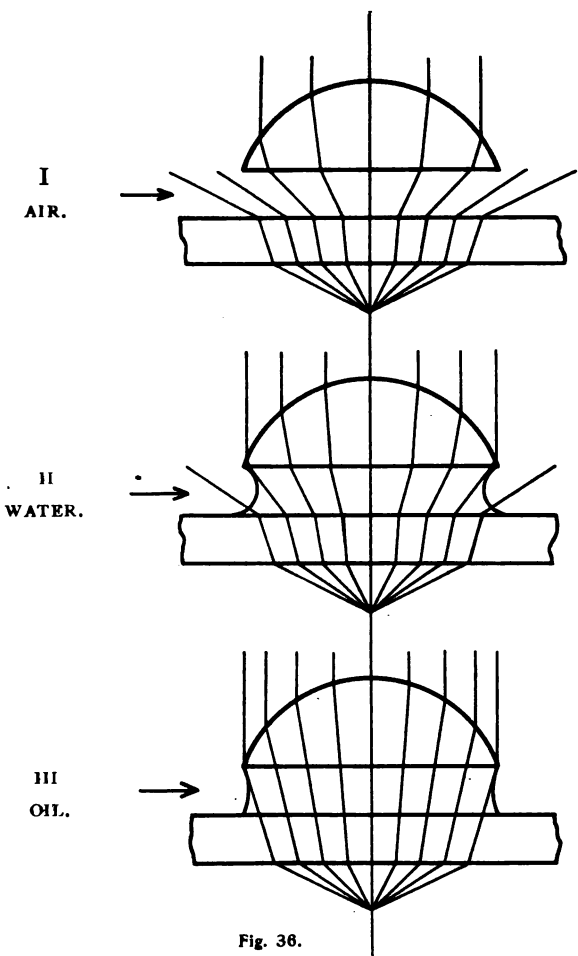

Fig. 36.

Referring now to the diagrams and bearing in mind the course of rays from an object through a cover glass, we can follow out their action. In the case of a dry objective, we see that a portion of the rays coming from the top of the cover glass are so refracted that they pass outside of the front lens of the objective and are therefore lost. In the water immersion, however, the rays are less refracted. With the oil immersion the only refraction to be considered is that which takes place at the lower surface of the cover as from that point the rays pass without change of direction through the cover, fluid, and front lens, as far as the convex surface, where they are refracted and carried through the objective. From a view of the diagram it might appear that if the lens were enlarged in diameter more of the extreme rays which are otherwise lost might be utilized; but as it is apparent that the radius of the front lens must then be increased, we know that this will increase the focal length and consequently reduce the magnifying power.

**Numerical Aperture.** The consideration of the capacity of objectives to take up a greater or less number of rays diverging from a given object leads to the question as to whether any optical law may exist in relation to the angular aperture of objectives, under the different conditions of their use, either dry, or with water, oil, or any other immersion fluid, and Prof. Abbe has found that it is as follows:

*“The sine of one-half of the angle of aperture multiplied by the refractive index of the medium between the front of the objective and the cover, is equal to the effective semi-diameter of the emergent pencil at the point of its emergence from the posterior lens, divided by the equivalent focal length of the objective.”* This expression Prof. Abbe calls the *Numerical Aperture* and its great value lies in the fact that it serves to designate the efficiency of an objective as to the quantity of light or number of rays, essential for the formation of a perfect image, that can be utilized by it. It has been proven that the greater the value of the Numerical Aperture, the more perfect is the delineation of fine structure in minute objects and the greater is the degree of fineness of detail that can be seen. Also, if objectives have the same Numerical Aperture, no matter what their focal lengths and the intervening media may be, they will give equally good definition of fine structure.

When designated on objective mountings or used in tables, the term Numerical Aperture is abbreviated to N. A. The formula for computing Numerical Aperture is written,  $N.A. = n \sin u$ , where  $n$  is the index of refraction of the medium between front lens and cover glass, and  $u$  the half-angle of aperture. Since the media are air, water, or oil, it is necessary to know the refractive index of each, which is 1.0 for air, 1.33 for water, about 1.52 for oil, and for the regular crown glass is, closely, the same as for the oil.

This formula can be better illustrated by an example. Take an objective with an angle of aperture in air of 100 degrees, of which the numerical aperture is to be determined. The focal length of the objective is left out of consideration as the formula depends entirely on angle and index and it is evident that all objectives having this same angle, in this case in air, will have the same N. A.

Considering the angle  $u$ , it will be readily seen that this is one-half of 100 degrees, or 50 degrees. Now referring to a table of natural sines or to a table of logarithms it will be found that sine  $u$ , or the sine of 50 degrees is equal to 0.766, and as the intervening medium is air, the value of index  $n$  is equal to 1.0.

Substituting the above values in the formula, we have  $N.A. = (n \text{ or } 1.0) \times (\text{sine } u \text{ or } 0.766) = 0.766$ .

To make this computation we have always the value of the index of refraction at hand, but the angular aperture must be determined, and the method for accomplishing this will be given in a succeeding chapter.

As a rule the designation as to power and numerical aperture engraved on the mounting of an objective from a responsible firm can be relied upon as being quite close, the variations seldom being greater than is incident to accurate human handiwork, and such variations as do occur have little influence on the

optical capacity. It is manifestly difficult for opticians who produce large quantities of objectives to measure and suitably mark each individual product, particularly when the differences are at best slight.

It is easy to learn the numerical aperture of an objective after the angular aperture has been determined, as the various values for different angles have been computed and are issued in tables. Such tables can be found in the pages of the Journal of the Royal Microscopical Society and in the latest edition of Carpenter's "The Microscope and its Revelations,"

Before the numerical aperture was accepted as the absolute measure of the optical efficiency of an objective, it was known that an increase of angular aperture gave better results, but just why this was so, was not appreciated. So also was it difficult to understand that a dry objective of 180 degrees, a water immersion of 96 degrees, and an oil immersion of 82 degrees angular aperture had the same optical efficiency.

**How to Measure Angular Aperture.** With instruments in which the axis of the mirror-bar is in the plane of the stage and in which the circular part is graduated, the matter of measuring angular aperture is quite simple. It was recommended by Mr. Tolles, and has been carefully worked out by Dr. George E. Blackham. After the object has been focused upon, incline the body of the microscope to a horizontal

**position, remove the mirror with its bow from the socket and place therein, or by rubber band attach to the end of the bar, a toy candle at such height that the flame will be in the optical axis. The mirror-bar is now swung to the right and left to such an extent that one-half the field shall be illuminated, provided the object shall still be well defined, or to the point where the definition of the object shall appear impaired without regard to the illumination of the field. These limits will mark the efficient beam of light which passes through the rear system of the objective. In some objectives the rear system is larger in diameter than the effective beam of light transmitted from the object, which will permit stray rays to reach the eyepiece, but which have no value in forming the image and therefore are not to be considered. In instruments which have no graduated mirror-bar the matter becomes more difficult and less accurate.**

Another method is that of Lister. After the object has been focused upon, place the body of the microscope in a horizontal position and in front and some distance from it, a candle or lamp; if the latter, with the narrow edge of the wick toward the instrument, but level with the tube. Move the lamp on each side of the axis to a point as described in the foregoing method. Indicate the position of the center of the lamp at each extreme on the table and beneath the



instrument also a point situated vertically under the object. Connect these points and with a protractor measure the angle.

A very accurate method and one which can be carried out on all instruments is that suggested by Prof. Abbe and for which the firm of Carl Zeiss supply an apparatus which is called the *apertometer*, which consists of a semi-circular disk of glass having at its straight edge a beveled surface which reflects the light through a perforated disk into the objective. Two strips of brass which act as stops are placed on the arc and thus indicate the limit of aperture, which, as well as the corresponding numerical aperture, can be read off on the scale.

In the foregoing we have gone to some length in stating the importance of angular and numerical aperture and laid stress upon the influence which these factors have upon the efficiency of the objective. We shall now endeavor to explain what these attributes are which determine the value of an objective.

**Resolving Power.** Most important of all qualities in an objective is the resolving power, which is the power to show intricate structure and minute detail, it being of course understood that the objective is properly constructed so that defects shall not detract from this quality. It is of course clear, that no matter how great the numerical aperture may be, its effectiveness may

be injured by the presence of chromatic or spherical aberration or defective mechanical work, and it is a matter of no uncommon occurrence that in objectives of the same power and aperture there is a noticeable difference in resolving power; or in objectives of different numerical aperture, the one of less aperture will have a greater resolving power than the other. If we could accept the statements of makers as true ones, a portion of this work and a vast amount of literature would be unnecessary, but the writer has occasion to know that this is not the case and that there is a constantly increasing danger and tendency to allow small defects to pass, in spite of the fact that the general efficiency of the microscope has increased in late years.

*To resolve* a structure is to make it visible and the resolving power is in direct ratio to the numerical aperture and can be mathematically calculated. It can be studied from the aperture tables already mentioned. It will be seen that an objective with a numerical aperture of 0.50 will make visible only one-half as many lines in the same space as one with a numerical aperture of 1.0. This, it will be seen, refers only to the resolving power of an objective and makes absolutely no reference to its magnifying power. Now, as we know that the purpose of the compound microscope is to give magnifying power and that there is a certain structure which is not visible to the eye, how can we

reconcile this with the fact that numerical aperture only does it? Why, if this is true, should we use a higher power objective with a prescribed aperture in preference to a lower one of the same aperture?

The normal eye can see about 200 lines to the inch, or structures which are 1-200 of an inch apart and it is therefore evident that any structures under the microscope must be separated at least to this extent in the virtual image, in order that they may become visible. While we have shown that magnifying power may be increased

by increasing the power of the objective,

by increasing the power of the eyepiece,

by increasing the tube length,

we are limited in the last direction mainly by such length of tube as has been found convenient in the construction of the stand; in the case of eyepiece on the one hand by convenience in use and on the other by the fact that too great an increase causes an indistinctness, so that, although variation in eyepiece within narrow limits is admissible, we are compelled to select an objective which, with a medium power eyepiece, will give sufficient separation to structure and fine detail, that it will be visible to the eye without any undue strain.

**Chromatic Aberration.** Up to this point we have spoken of the correction of chromatic aberration by suitable use of flint glass lenses and for the purpose of not making the subject too complex, have purposely refrained from stating that *entire freedom from color is impossible* in the ordinary combinations of flint and crown glass. The correction is for only two colors of the spectrum, red and violet, leaving as a residue the other colors which appear as apple green and purple. These form the so-called *secondary spectrum* and on bright objects this can easily be discerned. For all ordinary purposes the presence of these colors is not prejudicial to the performance of an objective. The secondary spectrum becomes more pronounced in dry objectives of large aperture and when high power eyepieces are used. Even in properly corrected low and medium powers of medium aperture and high power immersion objectives it is noticeable, but certainly not to any extent to be objectionable, except when oblique light is used, provided of course that the other corrections are properly made.

Great care should be used in judging an objective by its chromatic correction and one should not be led to false conclusions by the amount of color which an objective shows. It has been a common experience with the writer to have objectives complained of which were properly corrected and which were excellent in every respect except that they showed the *secondary*

*colors*, so that it may safely be said, remembering that wide aperture involves a greater amount of color, that an objective showing the proper colors of green and purple and having proper resolving power may safely be accepted, or in the choice of objectives between one showing no color but having no resolving power, the other having color and resolving power, the latter is certainly the preferable one.

When colors of green and purple are not sufficiently pronounced on an object when the mirror is in central position, they will become more apparent when the mirror is swung to an oblique position, using any object suitable to the power of the objective, and preferably mounted dry.

*If the mirror is swung to the left, the object should be fringed on the right side with yellow-green and on the left with bluish color, or if the mirror is swung to the right the conditions are reversed.*

When the objective is not properly corrected it is said to be chromatically *under-corrected* or *over-corrected*.

It is well to state here, however, that, with the care which is exercised by reputable makers, objectives which deviate from the proper point of correction, or in which the under- or over-correction is so prominent as to be noticeable to one inexperienced in this work, are never allowed to reach the public. These remarks are not intended to discourage the student from testing

objectives for color correction; on the contrary we particularly recommend such tests as will tend to more critical judgment of the optical properties of the instrument and work in general. To aid those who have not had sufficiently long experience to reach correct conclusions, methods for judging color correction are given which should be applied to doubtful products; but the experiments should be repeated quite often before reaching a conclusion.

*To judge under-correction by central light, focus upon a coarse object and it will be found to have a distinctly bluish tinge. If not pronounced, by slightly increasing the distance between objective and object, the latter will show a blue color and by decreasing the distance an orange color.*

*To judge over-correction, after focusing on the object, this will show an orange color, or by increasing the distance between objective and object the orange will appear, and by decreasing the distance, the blue.*

*To judge color correction by oblique light: Under-correction will show when the mirror is swung to the left and the object is fringed with orange on the left and bluish on the right.*

*Over-correction is apparent when the object is fringed with blue on the left and orange on the right.*

Another method is that recommended by Naegeli and Schwendener in their work on the microscope. The

right half at the front or back of the objective is covered with black paper or tinfoil so that only the other or left half remains optically effective; take for an object a line or dot of light which can be easily produced by blackening one surface of a slide by smoking in an oil flame and drawing a line across it with a point.

*Under-correction shows when the image has on the right side a violet or blue border and on the left a red or orange colored border.*

*Over-correction shows on the other hand when the left side appears violet or blue and the right red or orange.*

**Spherical Aberration and Cover Glass.** As has been stated, there is a residue of chromatic and spherical aberration in all ordinary achromatic lenses and objectives. The use of cover glass influences the spherical correction and while not appreciable to any extent in low powers, it is very sensible in the medium and high powers. Referring to Fig. 37 it will be remembered that the rays from the object do not reach the surface of the objective front uninterruptedly but are changed in their course. If we make use of the same illustration and extend the refracted rays downward as shown by the dotted lines  $d e, f c, f' c, d' e$  until they meet at the axis, these points will be the apparent location of the object and will appear to meet in the planes  $e a$  and  $c b$  instead of at  $o$ . To neutralize

this condition the objective will require to be spherically under-corrected, by which is understood that the marginal rays will emanate from a point near the objective and the central rays at a greater distance from the

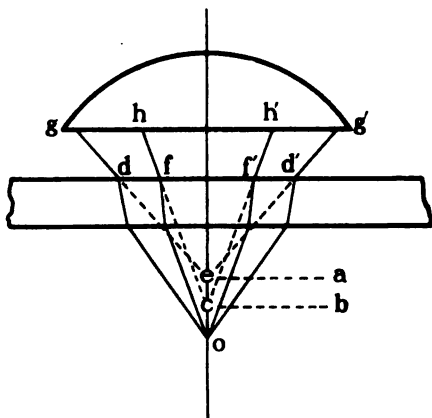

Fig. 37.

objective, or as is shown in the diagram, appear to come from exactly the same points, which are the apparent positions of the object or  $g e$ ,  $h c$ ,  $h' c$ , and  $g' e$ .

If a thicker cover is used the objective will require to be more under-corrected, or if a thinner one, less under-correction is needed, so that if an objective is corrected for a definite thickness of cover, its correction will be disturbed if greater or less thickness be used,



and since resolving power depends primarily upon the proper correction of the two aberrations, it will be *entirely lost* if there is much variation from the normal thickness.

It must not be forgotten that in microscopical work we are dealing with minute things and this applies especially to the cover glass. By studying the table which follows it will be noted that there is quite a difference in thickness used by the various makers, and that the mean thickness is 0.18 mm. or 0.007 inch.

The deviation from standard thickness affects the distinctness of the image according to its structure and in proportion to the increase in power. In the low powers there is no noticeable influence, but with the 1-5, 1-6, and 1-8 it is so marked that with objects of fine structure a deviation of 0.05 mm. either thicker or thinner than the standard is sufficient to totally obliterate fine structure and have the outlines and coarse lines only apparent. Slighter variations affect the image proportionately.

It is surprising to see how little attention is paid to this subject in the large majority of the standard works on the microscope. Almost all books give carefully prepared illustrations and descriptions showing the effect on the course of light of the interposition of the cover glass, and after giving conclusive evidence of its disturbing influence, still, in a general way, say it is of little moment.

It is a misfortune that cover glasses are not of uniform thickness, but the difficulties of producing them of equal thickness are almost unsurmountable, and it is also to be deplored that opticians have not agreed upon a standard thickness for which they correct their objectives. . The list herewith given, which has been prepared by Prof. Gage, will show the variations in thickness used by different opticians as standard.

$\frac{2.5}{100}$ mm.	}	J. Green,
		J. Grunow,
	}	Powell & Lealand,
		Spencer Lens Co.,
	}	W. Wales,
$\frac{2.0}{100}$ mm.		Watson & Sons,
$\frac{1.8}{100}$ mm.	}	Klonne & Muller,
		Bausch & Lomb Optical Co.,
	}	E. Leitz,
$\frac{1.7}{100}$ mm.		R. Winkel,
$\frac{1.6}{100}$ — $\frac{2.5}{100}$ mm.	}	Ross & Co.,
$\frac{1.5}{100}$ — $\frac{2.0}{100}$ mm.		C. Zeiss,
$\frac{1.5}{100}$ — $\frac{1.8}{100}$ mm.	}	C. Reichert,
		Gundlach Optical Co.,
	}	W. & H. Seibert,
$\frac{1.5}{100}$ mm.		R. & J. Beck,
$\frac{1.3}{100}$ — $\frac{1.7}{100}$ mm.	}	J. Zentmayer,
		Nachet et Fils,
$\frac{1.0}{100}$ — $\frac{1.5}{100}$ mm.	}	Bezu, Hausser et Cie.,
$\frac{1.0}{100}$ mm.		Swift & Son.

The cover glass may truly be called a necessary evil; for, while absolutely required in microscopical investigations, there is no adjunct to the microscope that has been and is productive of so much evil, and has done so much to retard the utilization of benefits made possible by the advance in the construction of objectives.

It must be remembered that the majority of objectives will always be dry, and it is an unfortunate circumstance that with this class of objectives the influence of variation in thickness of cover glasses is most apparent; but since it is so, all possible aid should be given to enable the student to obtain results which closely equal those obtained with the conditions under which the objectives were originally corrected.

With oil immersion objectives a variation in thickness is not very appreciable, provided, however, that the fluid is of the proper consistency, as there is practically no refraction between the cover glass, immersion fluid and front lens of objective. If the fluid, however, does not have the same refraction as the cover the spherical aberration may be as pronounced as with dry objectives, as it becomes more noticeable on account of higher power. It is therefore important to purchase the fluid from the maker of the objective or under a guarantee of the index of refraction.

Objectives with fixed mountings, such as are ordinarily used, in which the lenses have fixed relations

correcting the spherical aberration for a definite thickness of cover glass, will not permit of any change to correct for other thicknesses. With these, correction can be made within narrow limits by varying the tube length.

*For a thick cover the tube must be contracted; for a thin cover the tube must be extended.*

Objectives are, however, also constructed with a mechanical arrangement by which the distances between the lenses may be varied and are then called *adjustable*.

*For thick covers the lenses are brought together, or the adjustment is closed.*

*For thin covers the lenses are separated, or the adjustment is opened.*

In order therefore to obtain the highest efficiency of an objective, a cover glass should be used which has the same thickness as the standard used by the maker of the objective. Covers of standard thickness may be purchased, but the cost will be considerably higher than for the thicknesses regularly listed.

The best plan is to purchase a cover glass guage by means of which the thickness may be accurately measured. Under this plan we recommend the following procedure :

*Select standard thickness and use with high and medium power dry objectives. Thicker covers use*

*with low power objectives; thinner covers use with oil immersion objectives, as increased working distance is obtained.*

**Penetration.** Penetrating power is the quality which enables us to look into an object—to observe different planes at one time. It depends upon magnifying power and angular aperture, and decreases with the increase of either of these properties. Objectives are generally not constructed with any reference to it; it is, rather, a natural consequence of certain qualities of the objectives.

Penetration and resolving power are antagonistic, or at any rate in an inverse ratio, and can only be combined in a definite proportion. In two objectives of the same power and aperture, one cannot have penetration as a special feature and the other resolving power; they will be similar in these qualities provided they are similarly corrected. However, if they are not similar in their angular aperture, the one of smaller aperture will have more penetration than the other. In objectives of the same angle but different power, the one of low power will have in itself more penetration.

Low power objectives have a proportionately greater penetrating power than medium or high powers. In an object of considerable thickness, different planes can be observed at one time without focusing on them and we thus obtain an appreciation of form which is

impossible in the higher powers, as in these, focal adjustment for different depths is required.

Furthermore the accommodation of the eye is also a factor as it varies with different persons and thus, to a certain extent, is a matter of individuality.

**Flatness of Field.** The field of view or in brief the field in a microscope is the area which is observed by looking into the eyepiece. While its area is constant in an eyepiece, the size of the area being determined by the diameter of the diaphragm, it is variable with the change of objectives, the field or visible portion of the object becoming smaller with the increase in power. Angular aperture has no influence on the size of field. The field is said to be flat when all the parts of the image within its area are sharp at the same time.

When not flat, it will be found that as the edge of the field is approached the image becomes more and more indistinct, and that the objective must be correspondingly adjusted; in many cases it remains indistinct or blurred, and this may be considered a most serious fault. Lack of flatness may be due to the unevenness of the object, and in order to test the objective for flatness, an object of assured flatness should be used, such as a stage micrometer which consists of a series of very fine parallel lines cut into glass and very accurately spaced according to definite

fractions of millimeters or inches. After focusing upon the lines, they will appear to become more curved and less distinct as they near the edge, as shown in Fig. 38.

Flatness of field mainly depends upon the correction of the spherical aberration and, as under the best

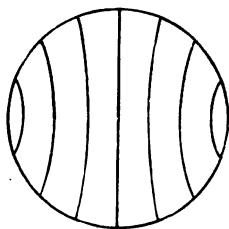

Fig. 38.

conditions this cannot be entirely eliminated, it is impossible to obtain absolute flatness. It may also, however, be due to a faulty eyepiece; in this case it can be determined by observing whether it shows equally in different objectives. With beginners, especially, it is usually most complained of, owing probably to the fact that it is most easily discernable. While it is a desirable quality and indicates to a considerable degree the quality of objectives, it is *impossible to obtain absolute flatness of field* in objectives of sufficient angular aperture to meet the requirements of the present day and especially in higher powers.

**Working Distance** represents the free space between the front lens in the objective and the upper surface of the cover glass which protects the object, when the objective is in focus and is corrected for that cover glass.

In objectives of low power, it is of little consideration, but with those of medium and high power, where it must be expressed in 0.01 or 0.001 inch, it becomes a matter of importance.

*Working distance* is spoken of as being *long* or *short* and varies with the power and angular aperture. Generally the working distance decreases with the increase in numerical aperture and becomes greater as the aperture becomes smaller. It was for a long time considered that these two qualities varied according to a fixed rule, but this at the present time is not considered to be the case. While in objectives of the same aperture it may vary considerably, in others of different aperture the higher one may have the greater working distance. The skill of the optician must, to a considerable degree, determine the amount of it.

It will be seen from the above that working distance stands in no direct relation to the focal distance of the objective and it may be added that it is *never as great as the focal distance of a simple lens* of the same magnifying power.

As may be imagined, there is a variety of opinions as to what constitutes long or short working distance in a certain objective. No definite rule can be laid down for this, as it is conditioned on the skill and requirements of the manipulator. It has several times occurred in the experience of the writer that objectives were



complained of as having no working distance (that the objective could not be focused) when on investigation it was found that very thick glass had been used as cover glass.

There is no question about the desirability of a long working distance in the higher power objectives, as the comfort of working is greatly increased and the danger of injury to the objective and also the object which may sometimes be a rare specimen is further removed; but, unfortunately, the difficulty cannot be eliminated and must be reckoned with. It is therefore important for the student to know the amount of working distance, so as to make allowance for it in focusing the objective, and to know the limit of thickness to use with high power objectives.

The actual measurement of working distance in microscopes having a graduated micrometer screw is simple and may be determined as follows:

*Lower the eyes to the level of the stage and bring the front of the objective very carefully just in contact with the top of the cover glass. Note the division on micrometer screw and by an upward focusing turn of the screw bring the object in focus and read off the distance traversed.*

*With an oil immersion objective follow the same process by bringing the objective in contact with the*

*cover glass while dry, then separate slightly and, inclining the instrument, allow some of the oil to drop in the space, then focus and read off. Divide the number of graduations on the screw head by the pitch of the screw and multiply by the number of divisions read off.*

**Magnifying Power.** This is a question of vital importance in a microscope, not so much as a quality in itself, as in connection with the resolving power. The inquiry should not be simply, how many diameters an instrument will magnify, but what the precision and extent of its definition is under a certain magnifying

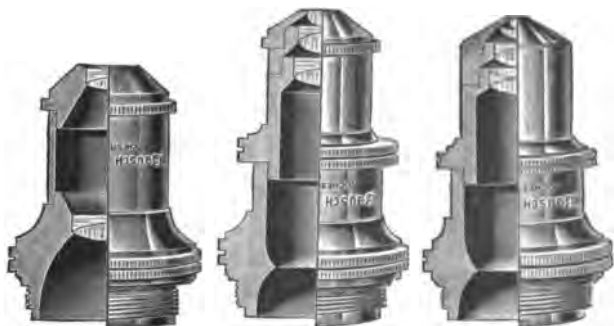

2-3 inch Objective.

1-6 inch Objective.

1-12 Inch Oil Immersion Objective.

power. If a high magnifying power is all that is desired, this may be obtained to an almost unlimited extent by means of simple lenses which may be pro-

cured at a small pecuniary outlay; but these do not give a distinct image nor do they make structure visible, which, be it remembered, it is the purpose of the microscope to do.

The normal eye can distinguish about 200 lines to the inch and in a microscope such magnifying power should be used as will apparently separate the structure which it is sought to see at least to this extent. To illustrate, take a 1-6 inch objective of 0.85 N. A. and a 2 inch eyepiece. An objective of this kind, properly corrected, resolves the test-object *Pleurosigma angulatum*, in which the lines average 60,000 to the inch. With the above eyepiece it is utterly impossible to see them, while if it is replaced by a 3-4 inch or 1-2 inch eyepiece, they can easily be distinguished. This is not owing to any peculiar quality of the eyepiece, but merely to the fact that by increasing the magnifying power the dimensions of the object have been increased and the spaces between the lines have been separated sufficiently to become visible to the eye.

Beginners as a rule are apt to use too much magnification, or *amplification*, and often attempt to view a large surface with an objective which will show but a small part of it. It must not be forgotten that the apparent field of view is decreased as higher powers are used and that a low power will give a better impression of a large, coarse object and its relative parts, because it makes a larger surface visible.

*Objectives of the same power, but having different angular apertures, will always have the same magnifying power and field.*

The following table will probably be of assistance to the beginner. After he has become better acquainted with his instrument his judgment will dictate to him what to do.

*A power of 25 diameters will show a surface of about 1-5 inch diameter.*

*A power of 50 diameters will show a surface of about 1-10 inch diameter.*

*A power of 100 diameters will show a surface of about 1-20 inch diameter.*

*A power of 500 diameters will show a surface of about 1-100 inch diameter.*

*A power of 1000 diameters will show a surface of about 1-200 inch diameter.*

This table is approximately correct with a Huyghenian eyepiece.

As has already been shown, magnifying power may be obtained by using a higher power objective, or eyepiece, or lengthening the tube, and it has also been pointed out that *the objective should be relied upon to obtain this increase.*

*Objectives with the same angular aperture, but of different power, will have the same resolving power.*

In both objectives and eyepieces the lenses decrease in size with the increase in power and consequently gather less light and while this one objection exists in the objective, an additional one occurs in the eyepiece, in that the eye must be brought closer to the eye-lens and must be kept more strictly in the optical axis, which at a long sitting, becomes fatiguing.

Choice of eyepiece should be determined by requirements and individual preference, but the use of high power eyepieces should be avoided whenever possible. All responsible makers of microscopes make up such outfits of stands, objectives, and eyepieces as experience has taught are most efficient and convenient.

In all work on recognized forms (objects of which the structure is known) it is safe to follow the rule, *not to use a higher power than is necessary to properly study them.*

**Apochromatic Objectives.** All achromatic objectives have a residual chromatic and spherical aberration, the former being the *secondary spectrum*; but Prof. Abbe has in this direction also effected a notable improvement, which with a uniform correction of the spherical aberration corrects for *three colors*, thus resulting in a closer concentration of image-forming rays which with the greater numerical aperture made possible by these conditions results in a higher resolving power. It has been found, however, that, in high

powers of wide aperture, even with these objectives there is an outstanding error which by itself cannot be corrected. This is balanced in the eyepiece, which is correspondingly over-corrected, and is called the *compensating eyepiece*. It has therefore been necessary to make the low powers under-corrected as well, so that they may be used with the same eyepieces, for it is evident that neither these objectives with the Huyghenian eyepiece, nor the compensating eyepiece with the achromatic objectives will give satisfactory results.

The proper combination of apochromatic objective and compensating eyepiece gives a beautiful image with the maximum of resolving power, unapproached by any of the achromatic combinations. They furthermore have the advantage that they are exactly suited to photomicrography, there being exact coincidence between the photographic and visual image, which in the achromatic objectives is not the case, as these must be either corrected for photography, when they are not satisfactory for ordinary purposes, or an allowance must be made for the difference between the visual and chemical images in the camera, which is very difficult.

One objection to the high powers has been the liability to deterioration of some of the materials used, which has happily been overcome by Prof. Chas. S. Hastings in the apochromatic objectives computed by him.

**Eyepiece or Ocular.** The purpose of the eyepiece is to refract the diverging rays coming from the objective so that they will reach the pupil of the eye and at the same time magnify the image formed by the objective. While it is the most simple part of the optical combination of the microscope it is, withal, an important part of it. In fact it may be said that, owing probably to its simplicity, it has been neglected, and very often eyepieces are furnished which are not at all commensurate with the quality of the objectives.

**Designation.** While eyepieces are still marked by some makers arbitrarily without any relation to their optical value, a rational system is to mark them according to the equivalent focus of the two lenses.

Thus an eyepiece marked 1 inch has an initial magnification of ten diameters, a 2 inch, five diameters, and so on.

**Field of View.** As has been stated this is the visible area which is limited by the size of the diaphragm.

While the relative size of field in eyepieces of different powers is the same, the actual field of view as it relates to the image becomes less as the power of the eyepiece increases. Thus if a 1 1-2 inch will show 1-10 inch of the object within the limits of the field, a 3-4 inch will show only 1-20 inch. By some

persons it has been supposed that an enlargement of the microscope tube would permit a large field, but this is not so in ordinary eyepieces as the optical conditions

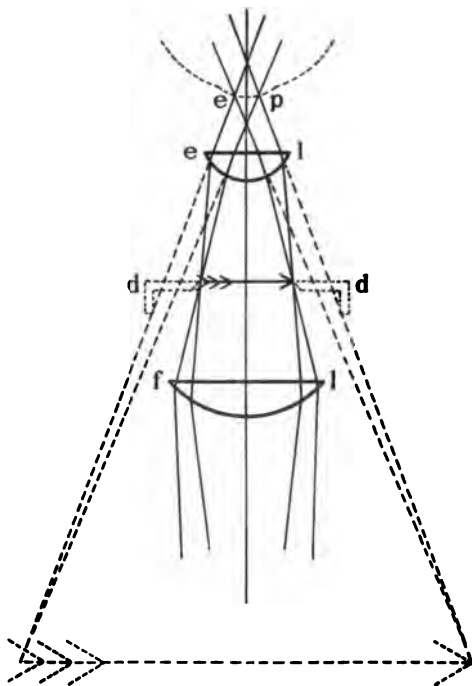

Fig. 39.

prescribe well defined limits and larger field can only be obtained with specially constructed eyepieces.



**Par Focal Eyepieces.** Important as it is to have objectives par focal, it is fully as much so with eyepieces as they are often changed with the same

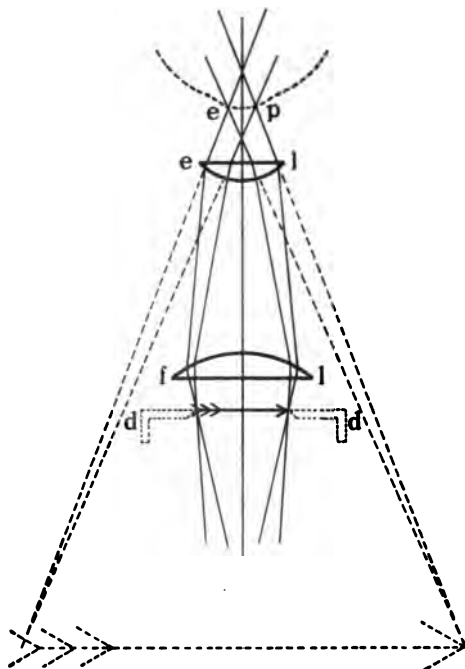

Fig. 40.

objective to obtain a change in magnifying power. It is a great convenience to use one or another without

disturbing the focus more than the fine adjustment will easily rectify.

Eyepieces are divided into two classes :

*Negative eyepieces*, Fig. 39, in which the focal point is within the eyepiece itself and between eye lens  $e l$  and field lens  $f l$  or at the diaphragm  $d d$ .

*Positive eyepieces*, Fig. 40, in which the focal point is outside and below the field lens  $f l$ . These eyepieces can be used as magnifiers.

**Huyghenian Eyepiece.** This form is named after Huyghens, who is said to have first used it. It is the construction which is in most general use, although made up in a variety of mountings. It is negative and consists, as has already been stated, Fig. 39, of an *eye lens*,  $e l$ , nearest the eye, and a *field or collective lens*,  $f l$ , which is the large lens nearest the objective. Between them and placed at the focus of the eye lens is a perforated, blackened disc, called a *diaphragm*,  $d d$ , which limits the size of field and shows it within a sharply defined border. The Huyghenian eyepiece is made in two forms :

The *English type* as shown in Fig. 41, which has a large tube fitting into the microscope tube and a neck or smaller tube which is usually arranged with a cap to slide over the eye lens.

The *Continental type*, Fig. 42, has a straight tube which drops entirely into the tube of the microscope and rests upon the mounting of the eye lens.

**Solid Eyepiece** is also a negative eyepiece and is the invention of the late Robert B. Tolles. It is called solid, from the fact that instead of being composed of two lenses, it consists of one piece of glass, Fig. 43, which is cut to a cylindrical form and on the ends of which the proper curvatures are ground and polished. The diaphragm is made by cutting a circular groove into the glass at the proper distance between the two surfaces, which is then filled up with an opaque pigment.

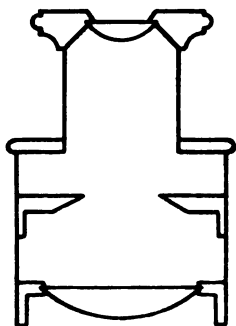

Fig. 41.

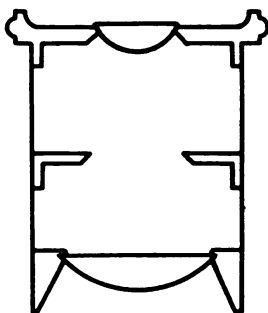

Fig. 42.

These eyepieces are made only in high powers, as optical glass is usually not of sufficient homogeneity to make low powers, and their cost would be too considerable without a corresponding advantage. They are usually made only in powers of 1-2 inch and stronger and for this reason have but a limited use.

**Ramsden Eyepiece** is a positive eyepiece, Fig. 40, and is constructed of two plane convex lenses with the convex surfaces toward each other. It is especially useful as a *micrometer eyepiece* in microscopes and telescopes, as it is used as a magnifier on the fine divisions of the micrometer and at the same time gives the virtual image.

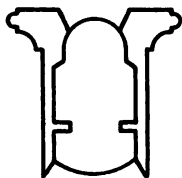

Fig. 43.

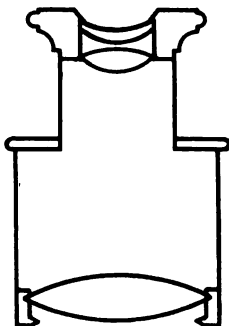

Fig. 44.

**Periscopic, Orthoscopic and Kellner Eyepieces** are also positive eyepieces which are achromatized by having the eye lens a doublet or triplet. The spherical correction is such as to produce a large and flat field, Fig. 44.

**Projection Eyepiece.** This is constructed to throw an enlarged image on a screen at a distance from the instrument and for photographing the image.

For neither of these purposes can the ordinary eyepiece be used. It is provided with a mechanical means of varying the distance between the eye and field lens for the purpose of changing magnifying power.

**Micrometer Eyepiece.** A micrometer is a strip of glass upon which a series of regularly spaced lines are ruled having definite values in fractions of an inch or millimeter and is used to measure the size of an object. When used with the eyepiece it must be situated in the focus of the eye lens and rests either upon the diaphragm or in slots provided on opposite sides of the mounting.

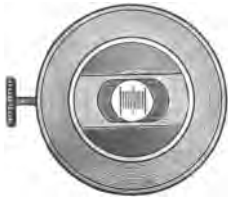

Fig. 45.

Another form is one in which the micrometer is a permanent part of the eyepiece and is provided with a screw adjustment to move it to different points in the field of view, Fig. 45.

**Binocular Eyepiece** is one constructed to bisect the beam of light which comes from the objective, thus rendering the image visible to both eyes and producing a stereoscopic effect. It is applicable to the monocular microscope.

**Erecting Eyepiece** is composed of four systems of lenses instead of two, some of which are sometimes

made achromatic. As the regular eyepiece of two systems reverses the image, the erecting eyepiece again reverses it, thus bringing the image back to the original position of the object. It is seldom used with the microscope, but is necessary with small hand telescopes and in the telescopes of surveying instruments.

**Index Eyepiece** is one which is provided with an index or pointer to indicate a particular object in the field or a certain structure of an object and is especially valuable in class demonstration. The index can be swung in and out of the field at will. Any of the Huyghenian eyepieces may be converted into an index eyepiece by cementing with shellac or Canada balsam an eye-lash or sharp black paper wedge to the diaphragm with the point toward the center of the field.

**Compensating Eyepiece.** In this place it is also proper to speak of the new compensating eyepiece as made by Prof. Abbe. This eyepiece compensates for the residual errors in the apochromatic objectives and is of no value except when used with them as it is highly over-corrected, as can be seen at the edge of the field, which has a strong orange color, whereas in the Huyghenian it has a blue color.

In this series of eyepieces there is a *searcher* which is of low power and intended to find objects. The higher powers are for general work, some of them

being negative, the others positive. Another kind is the *projection eyepiece* which is intended for projecting an image on a photographic plate, or on a screen or wall.

**Defects.** As has been stated many eyepieces are carelessly constructed and possess defects which interfere with obtaining a distinct image. These defects do not show easily with low power objectives, but can readily be seen with high powers. The most frequently occurring fault is the lack of perfect grinding and polishing of the lens surfaces. If the former, it will show itself as spots in the field, and if the latter, as a series of streaks and shadows, usually circular in form as if the lens had been wiped with greasy fingers.

Another defect may be in the glass itself, in the so called *striae*, which will be indicated by dark and light streaks across the field.

Care must be taken not to confound small particles of dust which are apt to fall upon the field lens and which at times are very prominent in the field, with imperfections of the surface. These can be distinguished from other defects only by wiping, or using a camel's hair brush, and even with the utmost care some particles are liable to remain.

The eyepiece often fits too closely in the tube and when making observations with high powers, a change of eyepiece is apt to disturb the object. It should

enter without any friction and still fit so closely that it drops slowly into its place from the compression of air in the tube when the objective is attached.

In the course of time a film is apt to form on the surfaces of lenses, which will cause indistinctness in the image. It is advisable to periodically unscrew both eye and field lens from the mounting and carefully wipe the inner and outer surfaces. In conclusion it may be said in a general way that the layman has rarely the fundamental knowledge and sufficiently long experience to judge critically of imperfections which may exist.

The idea is quite prevalent that there is a wide variation in objectives of the same type from the same maker. While this is quite true as between objectives of different makers and also of makers whose processes of production have remained the same as those of former years, it is not so with the products of those progressive firms who by common consent stand at the head in their respective countries. Precise and delicate as the various stages of production are, rigid control and inspection removes all personal factors and eliminates all chance in the final result. We do not mean to argue that the work of the best should be unquestioned ; on the contrary, it is advisable to examine all work critically, and preferably by comparison, and we are sure progressive makers will welcome all efforts in this direction and will lend their aid to a more intelligent use of their products.



## HOW TO WORK.

**How to Set Up the Instrument.** Draw the instrument from the case by grasping the base and pillar, free it from dust with a large camel's hair brush 1 inch or 1 1-2 inch wide or by wiping carefully with a chamois skin or old linen handkerchief. Place the instrument on the work table, which should be of such height that observations can be made with the utmost possible comfort without straining the neck or compressing the chest. Bear in mind always to sit as upright as possible.

If the instrument is used in the upright position, place the base close to the edge of the table; if inclined, it may set farther in. Rest the arms, as much as the height of the instrument will permit, upon the table.

Bring the tube to the standard length for which the objectives are corrected. To do this grasp the milled edge of the draw-tube and give it a spiral motion while holding the main tube with the other hand, page 50. There is an objection, however, that in any but cloth-lined sheaths the polished tube will soon be scratched,

especially if not kept very clean. In stands without the graduated tube, a mark or ring is or should be provided on it, which should be made to coincide with



Correct position at the microscope.

the upper end of main tube. Where the graduated draw-tube is provided bring the proper figure, either

216 or 160, in line with the upper end of the main tube, in accordance with the tube length for which the objectives are corrected.

*Attach low power eyepiece.*

*Attach low power objective.*

*Place object on stage.*

*Illuminate object.*

*Focus on object.*

**To Attach Eyepiece.** The exterior surfaces of the eye lens and field lens being exposed are apt to become dusty and should *always be carefully cleaned before using*. If there are two or more eyepieces, always use the lowest power first. Eyepieces should be so loosely fitted that they will drop into the tube as far as the collar *by their own weight*. They do this slowly when the objective is attached, as an airtight compartment is formed and air to the extent of the dimensions of the eyepiece must first be expelled from the tube. This displacement of air may, however, be hastened by gently pushing the eyepiece downward, but not to such an extent as to push in the draw-tube, or force down the coarse adjustment. In fact, care must be used in applying the eyepiece, or sliding the draw-tube, as the focus may be disturbed, or the objective forced against the object and thus destroy it.

**To Attach Objective.** Using a low power objective, remove from its box and see that its front lens is clean; elevate the tube of the stand by means of the coarse adjustment so that the nose-piece shall be at least two inches from the stage.

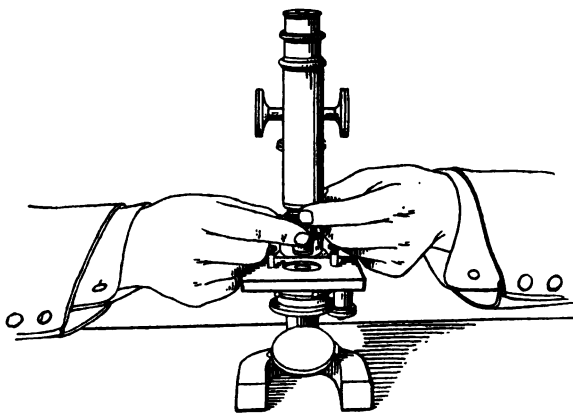

Proper manner of holding objective when attaching it to tube.

*Grasp the upper knurled edge of objective between thumb and forefinger of the left hand; bring the screw in contact with the screw of the nose-piece and, keeping the objective in line with the tube and gently pressing upward, revolve the objective with the thumb and forefinger of the right hand by the lower milled edge until shoulder sets against shoulder.*

To properly attach an objective is not always simple and *can not be done too carefully*. One danger lies in the fact that the objective may be dropped onto the object and thus injure or destroy one or the other or both, and another that the threads may be started wrong by holding the objective sideways and the threads injured.

In this connection we draw particular attention again to the convenience of the double, triple and quadruple nose-pieces. The convenience which is obtained from their use, freedom from danger to objectives and saving of time, commend them in all cases where two or more objectives are used.

**Finding an Object.** The slide upon which the object is mounted is placed upon the front of the stage and slipped under the two spring clips to a point where the object comes as nearly as possible in the center of the opening of the stage. The slide should pass easily under the clips, which, however, is not the case when the forward ends of the clips are too bluntly rounded or when they are too stiff. In either case the clips may be bent so that the slide will work easily. Some persons prefer to work without clips, but this can only be done after considerable experience has been acquired and only when the instrument is in an upright position.

With the low power objectives, which are used on coarse and large objects, it will be found after properly focusing, that a portion of the object will show itself in the field and by moving the slide it can easily be brought to the center. In this connection it must be remembered that the image in the eyepiece is in a reversed position from that of the object and that a movement of the object to the left gives an apparent movement to the right in the field. This will create confusion at the outset, but after a little practice the movement becomes involuntary. In the case of a small object which is not found after the objective is known to be in focus, as may be told if the mounting medium or small particles of dust on the cover glass are visible, move the slide about on the stage by grasping one end with the thumb and forefinger, when the object can usually be recognized by the shadowy outlines as it flits across the field. The difficulty of finding an object or a particular spot in it becomes more difficult with the increase in power and even in experienced hands becomes quite vexatious. Recourse may be had to two methods :

*By using a low power eyepiece,*

*By using a low power objective as a finder.*

A large field is thus obtained in which the object may be more easily found, and after moving to the center of the field the objective is removed and the high power attached ; or in case revolving nose-piece

is used, use the low power objective as a finder then swing the high power objective into position, care being taken not to touch the slide, and focus in the manner to be described. The object may not be in the field, due to a slight variation in the centers of the objectives, but it will certainly be very close and ought to be easily found.

The mechanical stage in either the fixed or attachable form will be found to greatly facilitate work in this direction, particularly if the object is minute and if in an important investigation one desires to be absolutely convinced that the whole field has been covered, as for instance in the search for bacilli.

**To Illuminate the Object.** This is an extremely important feature and should always be carefully done, as one may easily fail to obtain the best results, may be led to wrong conclusions, or may injure the eyes.

The mirrors of the microscope are usually plane and concave and are provided with universal joint, so as to reflect the light from any source in front or at the side of the microscope.

The plane mirror, Fig. 46, reflects the light in the initial intensity of its source and is used with low power objectives. The concave mirror, Fig. 47, concentrates the rays on the object and thereby gives intensified illumination and is used with medium and

high power objectives, except when substage condenser is used, which subject is left for future consideration.

The sources of light are either daylight or artificial light. In the former the light from a northern sky is preferable and in the latter a flat-wick oil lamp, or a Welsbach gas burner. An ordinary gas flame should not be used on account of the difficulty of obtaining equal illumination and the constant flickering which is very injurious. When using the flat-wick lamp the narrow edge of the flame should be used, as this is more intense than the broad side.

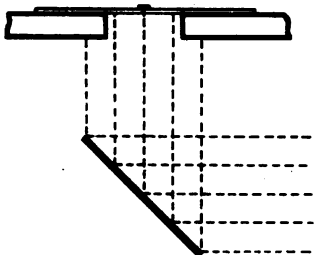

Fig. 46.

Illuminating object with plane mirror.

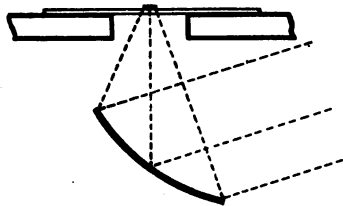

Fig. 47.

Illuminating object with concave mirror.

When using daylight place the microscope, as nearly as possible, directly before a window, and when a lamp is employed have it on the table either in front or at the right side of the microscope and within easy reach.



Light is either *transmitted* or *reflected*. When the former, it is used to illuminate transparent objects and passes through the objects from below the stage into the objective. In opaque objects this is impossible and reflected light is required, when it is directed onto the object from above and illuminates its upper surface. In the following instructions it is assumed that transmitted light is used unless otherwise stated.

The concave mirror converges the light and therefore has a focal point, and it is evident that if its focus is of such length that with parallel rays (daylight) it will fall on the object, the focus will be longer with diverging rays (lamplight) and when no provision is made in the instrument to adjust the mirror to meet these two conditions, it becomes difficult and sometimes impossible in critical work to obtain the best results. For this and other advantages an additional illuminating apparatus, called a *condenser*, is now commonly used with medium and high power objectives.

Before lighting an object make certain that the mirror-bar is in exactly central position and set the mirror at such an angle to the light that it will be directed upon the object, which can be done most quickly at the outset by observing the object directly, keeping the head at one side of the tube. Now remove the eyepiece and observe the light through the objective. It should be central and of equal intensity, which with daylight is sometimes difficult to obtain as

the sash of the window may be reflected and show itself in the field as dark bands, or in the case of lamplight the blue portion of the flame may appear as a dark spot. These are only preliminary directions but will suffice for a beginning. There will be little difficulty in obtaining proper illumination at the outset, if one will observe the following :

*Remove the eyepiece and, looking through the back of the objective, have*

*Central illumination,*

*Even illumination over the entire field,*

*Mellow illumination.*

Defects in illumination which may not be apparent will show when the eyepiece is replaced.

Defective lighting is indicated,

*When dark points or shadows appear in the field,*

*When the outlines of an object are bright on one side and dark on the other,*

*When the object appears to lie in a glare of light.*

In the first two cases the correction can be made by suitably adjusting the position of the mirror; in the last by reducing the amount of light by the use of a diaphragm.

It is now generally conceded that observations with the microscope may be made to any extent without

any detrimental results to the eyes, provided, however, that the conditions of light are just right. It is a good rule to follow, to use as small an amount of illumination as will comfortably show the structure which is being studied, and it may also be safely accepted that if the eye tires or feels uncomfortable the light should be moderated.

Illumination is either :

*Central or axial, when the center of the mirror is in the optical axis, or*

*Oblique, when the mirror is swung to one side which, in objectives of wide aperture, will disclose structure that cannot be seen with central illumination.*

**To Focus** an objective is to adjust its relation to the object so that a clear image is obtained. To properly and safely focus an objective is a matter of great importance and a certain line of procedure should be followed, which in time should become habitual. Focusing should involve no danger to the front lens of the objective or to the cover glass by their coming in violent contact. With the low power objectives, in which the working distance is great, there should be little danger; with the higher power objectives, in which the working distance is so small that the front of the objective is very close to the cover glass, there is considerable.

To focus low power objectives :

*Attach objective to the nose-piece. Lower the head to the level of the stage and, watching the front of the objective, lower the tube by the coarse adjustment until the front of the objective is within one quarter inch of the object ; look through the eyepiece and slowly elevate by the coarse adjustment until the image is distinct. Use fine adjustment.*

The upward movement should be slow so that if the object be faint it is not missed and the adjustment not run beyond its focal distance ; or it is possible that in the case of a very minute object it may be out of the center and thus out of the field of vision, in which case the surface of the cover glass or the minute particles of dust upon it should be distinguishable.

The object will first appear with faint outlines and indistinct, then gradually more distinct and finally sharply defined, and if the adjustment goes beyond this point it will gradually become more dim, in which case return to the point of greatest distinctness.

To focus high power objectives :

*Attach objective to nose-piece. Lower the head to the level of the stage and look between objective and cover glass toward a window or flame. Slowly lower the objective with the coarse adjustment until the front of the objective is nearly in contact with the cover glass ; look into the eyepiece and slowly elevate the tube with*

*the coarse adjustment until the image appears. Use fine adjustment.*

It is also advisable while watching for the image to appear to move the object slightly in different directions, as the flitting of shadows or colors across the field will give indications that the objective is nearing the focal point.

*Always focus upward.* In case a low power is exchanged for a higher power objective or when the low power has been used as a *searcher*, i. e., to find a certain object in a collection or a certain locality on a specimen, the tube should first be elevated as the working distance in the high power is too short to admit of screwing it into the nose-piece, then detach the low power, attach the high power and proceed to focus in the order given.

The method of procedure with the revolving nose-pieces, either double, triple or quadruple, is different. The writer believes he was the first to establish the commercial possibilities of making two and more objectives in revolving nose-pieces par focal, i. e., to so adjust the focus of each objective that when either one is swung into position it is nearly focused and requires the use of the fine adjustment only. This feature not only adds to the comfort of using objectives, but facilitates work and removes the danger of objectives coming in violent contact with the cover glass. Very low power objectives vary from those

powers which make up the usual outfit, and it is sometimes impossible to make them par focal. The 2-3 and 1-6 or 1-8 on the double nose-piece, and the 2-3, 1-6 or 1-8, and 1-12 oil immersion on the triple nose-piece can be so made. But in a combination of a lower power with the 2-3 and 1-6 on the triple nose-piece, or a lower power with the 2-3, 1-6 and 1-12 on a quadruple nose-piece, it is impossible to make the lower power par focal with the others on account of the considerably greater working distance.

As the adjustment of the objectives to make them par focal is quite delicate each screw in the nose-piece should be marked to correspond with the power of the objective which is to go into it.

To focus with double nose-piece :

*Screw each objective into proper place in the double nose-piece, with the 2-3 opposite the opening through which the light passes.*

*Hold the nose-piece in the right hand, objectives down; bring the revolving screw in contact with the screw in the tube, square with tube; with thumb and forefinger of left hand turn milled edge of revolving screw until it engages; swing nose-piece toward the front and, holding it in this position, screw the ring home.*

*Focus with 2-3 objective, then swing nose-piece until 1-6 nears the cover glass; lower the head to the level of stage; endeavor to slowly swing objective in*

*place. Should the front of objective come in contact with the cover glass or with the ring of cement on its surface the tube must be elevated and the objective focused.*

In the event of the objectives not being par focal, the difference in their focal distance should be noted for further use; if little, by the amount of turn of the micrometer screw, if considerable, by the extent of adjustment required with the coarse adjustment.

The method of procedure with the triple and quadruple nose-piece is very much the same as with the double, and the same rules will apply. In the case of oil immersion 1-12 objective apply oil to the front of objective before the nose-piece is screwed on the tube, and if after use the nose-piece is left on the microscope carefully wipe the oil from the objective.

In case the coarse adjustment is by sliding tube instead of rack and pinion elevate and depress the tube by grasping the milled edge between the thumb and forefinger, giving the tube a spiral motion. (See page 50.)

**To Focus with Fine Adjustment.** After the focus has been found with the coarse adjustment the fine adjustment should be brought into action, in order to obtain a more sensitive and reliable adjustment for focusing through the different planes or depths of the object. Its range of movement is necessarily short

and at one end the screw comes to a **stop** and at the other goes beyond the limit of movement and becomes inoperative. It should always be kept as near as possible *at the medium point of its range*. Grasp the milled head of the fine adjustment between the thumb and forefinger of one hand (right) turning the screw in either direction to focus in different planes of the object, while the other hand (left) moves the object.

“In the manipulation of the microscope it is not uncommon to observe the operator *rolling* the milled head of the *fine adjustment* instead of firmly grasping it between the finger and thumb and governing, to the minutest fraction of arc, the amount of alteration he desires. It is undesirable and an entirely inexpert procedure to roll the milled head, and cannot yield the fine results which a delicate mastery of this part of the instrument necessitates and implies. To use aright the fine adjustment of a first-class microscope is not the first and easiest thing mastered by the tyro. We have already intimated that the fine adjustment should never be resorted to while the coarse adjustment can be efficiently employed. The focus should always be found, even with the highest powers, by means of the coarse adjustment.” (*Carpenter, The Microscope and its Revelations.*)

**Use of Substage Diaphragm.** The intelligent use of the diaphragm is a great aid to good results,



and while a few hints can be given to guide the beginner, practice will, after all, lead to the best results. The purpose of the diaphragm is to modify the amount of light and by its aid obtain results in the definition of the object which without it are impossible. Much will depend upon the density of the object, the intensity of illumination, and the power of the objective. As already stated the plane mirror should be used with the low powers. The diaphragm of any form should be close to the upper surface of the stage, and if possible adjustable with respect to the object. This is to prevent any amount of extraneous light from the mirror reaching the object and not to shut out any of the useful light.

*Use an opening in the diaphragm of about the same size as the front lens in the objective.* As a rule this will be found to give a super-abundance of light, especially in the low power objectives, and by reducing the aperture it will be found that there will be an increased differentiation in the object. If in medium and high power objectives the illumination is insufficient, it is not due to the size of the diaphragm, unless this lies at a considerable distance from the object, but to the insufficiency of illumination. The diaphragm should be reduced to a point where the amount of illumination will be perfectly comfortable to the eye. Very often better results are obtained by varying the distance of the diaphragm from the object

and it is easily recognized when better definition is obtained in this way.

*Do not use so large an opening that there will be an uncomfortable glare, nor so small that undue exertion is required to see structure.*

When oblique light is used there should be no obstruction to the course of light. If a cap diaphragm is used with central illumination, it should be entirely removed with oblique illumination. With the iris diaphragm the full opening should be employed. In the case of the revolving diaphragm which generally is some distance from the object it should be removed if possible, and if not, the largest opening should be used.

**Which Eye to Use.** The right eye is generally used for observations, but while the manipulator may from habit be inclined to use this, it may be possible that in some cases the left can be used to better advantage and with less fatigue. It is a fact well known to oculists and opticians that many eyes are defective, of which fact the possessors may not be aware. Short or long sightedness has little or no influence in viewing an object, except to require a different adjustment, but so-called *astigmatism*, a defect of the eye which makes it impossible to see in a certain axis distinctly, may influence the best results. If this error is corrected by wearing glasses and these are used while making observations, either eye can be used.

But in order to determine whether a defect exists, of which the possessor is not aware, observe closely first with one eye then with the other an object, preferably one with fine striations such as a diatom, to learn whether with one eye a better view is obtained than with the other and use the one giving the best results.

*Make it a habit at the outset to keep both eyes open.*

There is one point over the lens called the *eye-point*, Fig. 39, *e p*, at which the rays cross within the smallest compass, and *this is the proper position* for the eye as the largest number of rays enter it. *When above or below this point* the size of field will be reduced or shadows or colors will appear in it. In low power eyepieces the eye-point is some distance from the lens; in high powers quite close to it—in fact in some so close that the eyelashes rest upon the lens and sometimes appear in the field as dark bars. Generally speaking the best point is where the entire field is seen and its margin (diaphragm) sharply defined.

**What Objects to Use.** Suitable objects for preliminary work in leading the student to a skillful use of the instrument and to give him proper judgment in testing the capacity of objectives are also valuable.

*Low Powers—Proboscis of blow-fly.* This should be flat and transparent. For 1 inch, 2-3 and 1-2 inch objectives the scales from *Lepisma saccharina*.

*Medium Powers*—*Pleurosigma angulatum*, dry, stained *Bacteria* and *Micrococci*.

*High Powers*—Oil immersion 1-10 inch and 1-12 inch objectives, *Amphipleura pellucida*, *Surirella gemma* in balsam or styrax. Stained *Bacteria* and *Micrococci*.

**Test Plate.** This will be an excellent acquisition for all those who can meet the pecuniary outlay. It consists of a series of twenty diatoms arranged according to the coarseness of the lines. They are furnished mounted both in balsam and styrax. Below is a table giving the numbers, names of the various diatoms and divisions on their surfaces in 1-1000 inch. A specimen of *Eupodiscus argus* begins and ends the series:

	Striae in 1-1000 inch.
1. <i>Triceratium favus</i> , Ehrbg., - - -	3.1 to 4.
2. <i>Pinnularia nobilis</i> , Ehrbg., - - -	11.7 " 14.
3. <i>Navicula lyra</i> , Ehrbg., var., - - -	14.5 " 18.
4. <i>Navicula lyra</i> , Ehrbg., - - -	23. " 30.5
5. <i>Pinnularia interrupta</i> , Sm., var., - - -	25.5 " 29.5
6. <i>Stauroneis phœnecenteron</i> , Ehrbg.,	31. " 36.5
7. <i>Grammatiphora marina</i> , Sm., - - -	36. " 39.
8. <i>Pleurosigma balticum</i> , Sm., - - -	32. " 37.
9. <i>Pleurosigma acuminatum</i> (Kg.) Grun.,	41. " 46.5
10. <i>Nitzschia amphionys</i> , Sm., - - -	43. " 49.
11. <i>Pleurosigma angulatum</i> , Sm., - - -	44. " 49.
12. <i>Grammatiphora oceanica</i> , Ehrbg., G.	
<i>subtilissima</i> , - - - -	60. " 67.

- |  |       |     |        |
|--|-------|-----|--------|
| 13. <i>Surirella gemma</i> , Ehrbg.,                       | - - - | 43. | to 54. |
| 14. <i>Nitzchia sigmoidea</i> , Sm.,                       | - - - | 61. | " 64.  |
| 15. <i>Pleurosigma fascicola</i> , Sm., var.,              | - - - | 55. | " 58.  |
| 16. <i>Surirella gemma</i> , Ehrbg.,                       | - - - | 64. | " 69.  |
| 17. <i>Cymatopleura elliptica</i> , Breb.,                 | - - - | 55. | " 81.  |
| 18. <i>Navicula crassinervis</i> , Breb., <i>Frustulia</i> |       |     |        |
| <i>saxonica</i> . Rabh.,                                   | - - - | 78. | " 87.  |
| 19. <i>Nitzchia curvula</i> , Sm.,                         | - - - | 83. | " 90.  |
| 20. <i>Amphipleura pellucida</i> , Kg.,                    | - - - | 92. | " 95.  |

Whatever opinion one may have in reference to the study of diatoms, the fact cannot be gainsaid that they have been a great aid in the improvement of objectives. They are used by opticians to judge the various characteristics of objectives and offer a reliable standard for testing resolving qualities, such as no other object can. The writer particularly recommends that the test *Pleurosigma angulatum*, dry, form a part of every outfit, not only as a test for resolving power but as an object for study with which to acquire skill in manipulating the microscope. It may be used with powers of 1-4 inch and higher and after it has served its purpose may be put aside for work with objects which come under the particular branch of study which one is following.

The writer wishes to counteract as much as possible the opinion, which is too prevalent, that the use of diatoms indicates microscopical play and is unworthy of consideration in histological and biological work; but

the fact that the optician deems them necessary for determination of optical qualities ought at least to indicate that they are a valuable adjunct and certainly will aid in giving greater manipulative skill.

At this point it is considered advisable to add some suggestions from Carpenter.

“The correctness of the conclusions which the microscopist will draw regarding the nature of any object from the visual appearance which it presents to him, when examined in the various modes now specified, will necessarily depend in a great degree upon his previous experience in microscopical observations and upon his knowledge of the class of bodies to which the particular specimen may belong. Not only are observations of any kind liable to certain fallacies arising out of the previous notions which the observer may entertain in regard to the constitution of the objects or the nature of the actions to which his attention is directed, but even the most practiced observer is apt to take no note of such phenomena as his mind is not prepared to appreciate. Errors and imperfections of this kind can only be corrected, it is obvious, by general advance in scientific knowledge; but the history of them affords a useful warning against hasty conclusions drawn from a too cursory examination. The suspension of the judgment, whenever there seems room for doubt, is a lesson inculcated by all those philosophers who have gained the highest repute for practical wisdom, and it

is one which the microscopist cannot too soon learn or too constantly practice. Besides these general warnings, however, certain special cautions should be given to the young microscopist with regard to errors into which he is liable to be led even when the very best instruments are employed."

**Medium Power Objective.** After sufficient time has been devoted to study with the low power objective, exchange it for the higher power and replace the object with the slide *Pleurosigma angulatum*. Focus upon this, being mindful of the suggestions previously given and do not fail to observe what has been said in regard to well illuminated field. Observe now whether any lines can be seen upon the surface of the diatoms. If not, vary the distance of the mirror from the object, if adjustment is provided for; or, if lamp-light is used, bring the lamp closer to or remove it from the instrument in one line so that the illumination will not disappear. If this does not bring out the lines, swing the mirror-bar from the central to an oblique position on the side opposite to that of the light and readjust the mirror. Grasp the ends of the mirror-fork between the thumb and middle finger and move the mirror with the first finger. If the field cannot be evenly illuminated, it is evident that the mirror is beyond the limit of angular aperture of the objective and must therefore be brought back until the light appears

equally well over all parts of the field. It must also be noticed here that if the diaphragm is still attached to the instrument and does not swing with the mirror, it may be the means of cutting off light. The largest opening should be employed or, if the cap diaphragm is used, this should be removed. By means of the micrometer screw carry the fine adjustment back and forth beyond the plane of the object and observe closely whether any lines can be distinguished. It is very probable that they will show, but if not, the cause should be determined. It may be that the magnifying power is not sufficiently great to make the lines visible and in this case a higher power eyepiece should be used; or the cover glass may be more or less than the normal thickness, which would cause a spherical over- or under-correction in the objective. In this case the lines would appear when the outline of the diatom is out of focus, and the structure will be more readily apparent with oblique than with central light. If the above directions have been followed, the lines ought certainly to appear with a moderately good 1-5, 1-6 or 1-8 inch objective, but if they are not, the trial should be repeated. Again, be careful to have no obstruction in the course of rays from the mirror to the stage; have good illumination on the object; observe well, and keep the instrument in such a position that the object is not illuminated from any other direction than from the mirror.



When the diatoms are *resolved* in this manner the lines will appear to be diagonal in some, longitudinal or transverse in others, according to their position, and if the resolution is very good, these lines will further resolve themselves into minute beads of a hexagonal form.

It will now be well to bring the mirror more nearly to a central position. Do this by intervals of about 10 degrees and note the appearance at each decrease of obliquity. It will be found that as the mirror approaches the optical axis the lines will appear to become more faint and may disappear before central illumination is reached; in this case it will be well to begin again. An endeavor should be made to make each attempt give better results than the preceding one. Repeated trials will not only impress the various phenomena upon the mind, but will cause a notable improvement in manipulative skill and thus a better performance in the objective.

**To Judge Spherical Aberration.** This is a matter of experience based upon the knowledge of the principles involved and after having been studied will be found to be of the utmost value in utilizing the capacity of a microscope. To judge spherical aberration by the use of histological or biological objects, without a previous knowledge acquired from objects which are more suited, is extremely difficult. One may be aware

by the unsatisfactory appearance of the image that something is amiss, but will probably not know how to correct the deficiency.

Using a 1-5, 1-6 or 1-8 inch objective and the test object *Pleurosigma angulatum*, select a diatom which is flat and locate in the center of the field. Focus carefully so that the margin of the object will be sharply defined and observe the markings. If they show in the same plane without any further focusing, the spherical correction may be accepted as being correct. *If the lines appear to lie in a higher plane and it is necessary to focus upward, so that the margin of the diatom is out of focus, it indicates spherical over-correction and the remedy is found in the contraction of the tube length.* This should be done progressively in spaces of about one-half inch, and after each change carefully focus again until proper correction is obtained.

*When the lines appear to lie below the plane of the object, it indicates spherical under-correction and can be corrected by increasing the tube length.* If there are two or more eyepieces, results can be obtained quicker with the higher powers.

If the markings cannot be seen, it may be due to abnormally thick or thin covers, a not uncommon occurrence, thus destroying the resolving power. This may be judged by using slightly oblique illumination. If too much is used the nice differences will be lost.

In all objects other than diatoms it is generally difficult to form an opinion as to spherical correction. If from preconceived idea of what an object should show it fails to meet expectations or is hazy where one expects it to be distinct, and being certain that the objective and eyepiece are properly cleaned, it may generally be ascribed to lack of proper correction. By focusing either above or below the proper focal plane there will be an enlargement of the outlines of the object or a *coma* which gradually enlarges as the objective recedes from the proper focal point.

*If the expansion is greatest when the objective is elevated, there is spherical over-correction and the tube length should be decreased.*

*Should the expansion be greatest when the objective is lowered, there is spherical under-correction and the tube length should be increased.*

**Chromatic Aberration.** This may be judged as described under "Chromatic Aberration" in a previous chapter, page 85.

**Cover Glass.** We have thus far not considered the cover glass, except to show its influence on the optical performance of objectives. In preliminary examinations of solid objects with low powers it may be dispensed with, but where fluids are used, whether with low, medium or high powers, it should always be

used. A drop or small quantity of fluid placed upon a slide assumes a spherical form and, on viewing it with a low power, it will be found to give a distorted field and cause disagreeable reflections and shadows.

In medium and high powers, the front lenses will be so close to the water, urine, blood, etc., that capillary attraction will cause an adhesion to the front surface of the objective; besides this, there is such a considerable depth to the fluid that it obstructs the light, requires a great change in adjustment for the various planes and is usually in such vibration that sharp focus becomes impossible. By merely dropping a cover glass upon it all these objections are overcome.

Covers are commercially classified as No. 1, No. 2 and No. 3, but there is a variation within the limits of different numbers. The variation is about as follows:

No. 1, 1-150 to 1-200 inch, or 0.16 to 0.13 mm. thick.

No. 2, 1-100 to 1-150 inch, or 0.25 to 0.16 mm. thick.

No. 3, 1-50 to 1-100 inch, or 0.50 to 0.26 mm. thick.

According to the prices of cover glasses, when purchased by weight, the No. 1 gives the greatest number and No. 3 the least. It may for this reason be thought that the purchase of No. 1 is most advantageous, but it must be considered that there is a greater amount of breakage by cleaning, as they are very thin and sensitive. Considered from the optical standpoint the No. 2 covers offer a range in thickness

to meet the different standards as used by the makers of objectives. Test objects which are prepared to test the resolving power of objectives and consist of diatoms are generally covered with these thicknesses. The No. 1 are principally used with oil immersion objectives as the working distance of these objectives is very short and more working distance is gained by using thin covers with them.

An excellent means of determining the thickness of cover glass, as well as of studying spherical and chromatic aberration, is the Abbe test-plate. This consists of a series of cover glasses ranging in thickness from 0.09 mm. to 0.24 mm., silvered on the under surface, with lines cut through the film of silver, and cemented to a slide, each cover being marked with its correct thickness.

*With this test-plate spherical aberration is corrected when the bands or lines show distinctly without any nebulous fringe, and thus indicate the proper thickness of cover to use.*

*Chromatic correction may be judged by the character of color bands which show with oblique light. But correction is indicated when, on swinging the mirror to the left, violet appears on the left and apple green on the right side of the bands.*

**Dry, Adjustable Objectives.** Adjustable objectives, or objectives with *collar correction* are those in which there is a mechanical provision to vary the distance between the lenses, in order to make with facility, proper correction for spherical aberration. They involve a high degree of mechanical perfection and are therefore more expensive than objectives with fixed mountings. They may, however, be recommended to microscopists who have acquired some experience in handling objectives and even to beginners who will use judgment in their use, as they certainly give excellent results and quick means for obtaining the utmost limit of efficiency in objectives, a fact best appreciated by those who are expert in the use of them. In these objectives, as at present constructed by the best makers, a milled collar is provided, which when rotated imparts a rectilinear motion to an interior tube carrying the posterior system of the objectives, thus varying the distance between them and the front system which remains stationary. The screw collar is graduated in such a manner that the figures indicate the correct point for the proper thickness of cover glass; thus 10 indicates proper correction for a cover of 0.10 mm., 16 for 0.16 mm., and so on.

*When set for thick covers, the lenses are closest together and the adjustment is said to be closed: when for thin covers, the lenses are farthest apart and the adjustment is open.*

In objectives of older construction and in some produced at the present day, the figures are arbitrary and serve no other purpose than an index for reference.

Close the adjustment before attaching the objective as its front may otherwise come in contact with the cover before the focus is reached. For practice with this objective use *P. angulatum*. Focus carefully and observe whether any lines can be seen; if not, grasp the milled edge of the adjustment collar between the thumb and first finger of the left hand, keeping the fingers of the right hand upon the milled head of the fine adjustment; turn the collar slightly toward its open point and, as this will place the object out of focus, move the fine adjustment correspondingly. Continue to turn the collar little by little and do not cease to observe closely; also, after each movement, focus above or below the plane of the object, so that this will be distinct, and look for the lines. Possibly after a little they will begin to appear faintly; but, if not, continue to bring the collar toward the middle point. The lines must now soon make their appearance, and when they do, it will probably be above the plane of the diatom. This is an indication that the objective is approaching its correction for the cover. Now keep the lines in focus, while the correction collar is being gradually turned, until the lines and the outline of the diatom lie in one plane. The objective is now said to be corrected for the cover used. Observe

which number corresponds to the index and, turning the collar back to its closed point, go through the same procedure as carefully as at first. When the best point is again reached look for the number and see whether it agrees with the first; very likely it does not, which is owing to a lack in the faculty of perception, due to a too slight acquaintance with the phenomena. These trials should be repeated until the proper sensitiveness of feeling in making the adjustments is acquired and until they can be made to correspond with certainty to at least within two divisions. When it is found after repeated trials that sufficient skill has been acquired, mark the number upon the slide. For future examination of the same slide, this will facilitate work and give the assurance that the best results are thus obtained without further trial by simply referring to the recorded number.

On stained Bacteria and Micrococci focus briskly with the fine adjustment to either side of exact focus. There will be an expansion of the outline of the object both when within and without the focus.

*If the greater expansion or coma is within the focus, or when it is necessary to raise the objective, there is spherical over-correction and the adjustment must be closed.*

*If the greater expansion is below the focal plane, there is spherical under-correction and the adjustment should be opened.*



When the proper point of correction is reached the expansion of outline is the same in both directions.

**Immersion Objectives.** As has been stated before, immersion contact between the objective and cover glass is made with either water or homogeneous fluid. With the former distilled water only should be used and kept in a suitable bottle. Cedar oil is used for the homogeneous fluid but is specially prepared, the commercial cedar oil being too thin and volatile and not of the proper refractive index. A small bottle is generally supplied with each oil immersion objective. *Great care should be used in keeping it free from dust, as it often happens that an objective fails to give satisfaction because of a small particle of dust which may float in the fluid in front of the hemisphere. Great care should also be exercised in applying oil to the front lens and after the application it is strongly recommended to examine it with a magnifier, that there may be no air bubbles present. Air bubbles as well as dust seriously interfere with obtaining satisfactory results. If bubbles are present the oil should be removed and a fresh quantity applied. An air bubble will entirely destroy the clear definition of a lens even when not directly in front of the lens itself. Care should also be taken not to apply too great a quantity. After the stopper has been withdrawn from the oil, allow the oil to run down the rod or brush until the*

*last natural drop has separated from it and apply the remainder, or less than a drop, to the front of the objective.*

Attach the objective and lower it until the fluid comes in contact with the cover, observe this by lowering the head to the level of the stage. Focus as with dry objectives. The use of immersion fluid in itself involves a certain amount of inconvenience, but the observance of fixed rules will materially help to overcome some of the disagreeable features. Extreme cleanliness should be observed with it. After the work has been completed the objective should be removed from the stand and its front as well as the slide should invariably be cleaned. The fluid may be removed by a moist piece of soft linen and the front then cleaned with a dry piece or with lens paper. Chamois skin is not suitable, as it does not absorb the fluid.

**Immersion Objectives on Test Plate.** Oil immersion objectives are not so sensitive to variations in thickness of cover, although many of the most expert manipulators prefer adjustable mountings in order to obtain the highest results.

To determine the highest capacity on test objects, ordinary daylight is not sufficient; a flat-wick oil lamp is best suited. If the right hand is used on micrometer screw, place the lamp at the right side of the

instrument, about ten inches from it, with the edge of the flame turned toward the mirror.

Place the test plate upon the stage and, as the diatoms in balsam are very transparent and therefore very difficult to find, a low power objective may be used as a finder ; bring No. 1, *Triceratium favus*, into the center of the field and after the low power objective has been removed attach the immersion objective, which we assume to be a 1-12, in the manner prescribed. Get the best possible illumination with the mirror at the central point and move the test plate from diatom to diatom until it reaches No. 11, *Pleuro-sigma angulatum*, but observe closely the structure of each one as it comes into the field. Next, see whether the objective is spherically corrected. If the lines and outlines, or middle rib, do not appear to be in the same plane, adjust the collar in adjustable or the tube length in non-adjustable objectives until they are, then continue the advance toward the higher numbers until one is reached on which no lines can be seen. Swing the mirror-bar to an obliquity of 20 degrees to the left side and, readjusting the mirror, observe the effect. It is very probable that the lines will show and if so, continue the advance ; if they do not, increase the obliquity of the mirror-bar 10 degrees or 20 degrees and after the structure comes out, again go forward. A point may thus be reached where with the greatest obliquity which can

be given and with the best possible illumination the objective seems to have come to the limit of its performance. From the claims which have been made for it, it ought to do better. What is the cause of failure? Possibly the mirror is not correctly focused, or the adjustment collar may not be correct for oblique light; perhaps the eyepiece does not give sufficient magnifying power to distinguish the *striae*. It may be any one of these causes or all combined. As to the eyepiece, the manipulator must remember the amount of separation of lines in the last object which was resolved and from the gradation in the coarser specimens must judge whether the power is sufficient; it should be added that for any over No. 14 and under No. 18 a 1 inch eyepiece should be used and for those above No. 18 a power of 3-4 inch for the long tube and of 1-2 inch for the short tube will be necessary. After this condition has been complied with, look to the correction collar of the objective. To obtain the highest results it very often occurs that a different adjustment is required for oblique light from that for central light. Note the number at which the collar stands and then work it back and forth, watching carefully for results. If this has no influence, return it to its number or to a point where the outline of the object appears most sharp. Now look to the illumination; vary the distance of the mirror from the object, or if this cannot be done, vary the distance of the lamp

from the instrument and watch the effect of the change through the eyepiece. If neither of these changes give any improvement, recourse must be had to another expedient. Place a bull's-eye between the lamp and mirror with the plane side of the lens toward the lamp and close to it, so that the light is thrown on the mirror. It should be properly concentrated, so that the circle of light will not be larger than the mirror, which can be determined by placing the hand or a piece of paper back of it. Adjust when necessary by moving the lamp or bull's-eye. Keep the mirror a little below the line of the top of the stage, so that the beam from the bull's-eye will not illuminate the object on its upper surface. If the direct light from the bull's-eye reaches the object, it destroys to some extent the effect of the oblique illumination from the mirror. Great care should be given to this point as it is very important.

If all of these suggestions have been followed, a great difference will undoubtedly be noticed in the performance of the objective; but if it still does not come up to the standard, patience must not be lost. The slightest change in the position of the mirror, or bull's-eye, or lamp, or a touch to the correction collar or micrometer screw, is sometimes followed by astonishing results. The beginner should sit down with the expectation that he will fail at the first trial. At each succeeding trial he can easily notice his improvement in manipulation and a corresponding gain in the results.

He should be able to bring the performance of the objective up to the claims made for it, if it has come from the hands of a reliable optician, and should not rest until this is accomplished.

The writer has often recommended sunlight with generally successful results where ordinary means of illumination have failed. The light is of course intense and great care will have to be used to modify it by properly using the mirror, but success is often attained and then creates confidence. It is, however, only recommended for this purpose and not for general use.

Stained Bacteria and Micrococci also make excellent objects for immersion objectives. The mode of illumination is the same as with dry objectives. Great care and judgment should, however, be exercised in forming an opinion as to resolving power from such specimens. Only the most carefully stained and suitably selected specimens are of any value, among the best of which may be mentioned the beaded form of *Bacillus tuberculosis*, *if clearly and deeply stained*. The enveloping structures of many bacteria and the diffusion of stain from them to the surrounding substances in which they are imbedded render them entirely useless for test purposes.

**Opaque Objects** are so dense in their structure that the light from the mirror below the stage will not pass through them. They generally consist of plants, minerals, shells, etc.

*Place the object on a slide and slip under the clips.*

In this case the low power objective is used for two reasons; because a general view is sought, involving low magnification and large field with light-giving power and because a higher power cannot be used on account of its short working distance. The light may and undoubtedly will be found insufficient to distinguish the object clearly. If the instrument is of the American type, swing the mirror-bar upon its axis

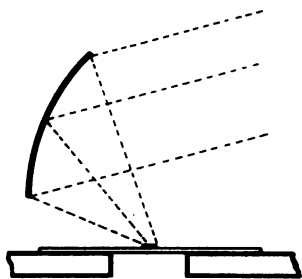

Fig. 48. Illuminating Opaque object with mirror above the stage.

around the stage to a point above it so that it will be at an angle of about 45 degrees to its surface. If a lamp is used and in the same position as when used for transmitted light, it is probable that the tube of the instrument will obstruct the light and it is then well to move it toward the front. Using the concave mirror, adjust so that the light will be concentrated upon the object, by watching it directly, and then observe through the tube. If it is not sufficiently illuminated continue to adjust the mirror; also vary its distance from the object and swing the mirror bar to a higher or lower point.

In the Continental form of microscope where there is no provision for swinging or placing the mirror above the stage, one is dependent upon the direct source of light when, in the case of lamp light, the lamp should be raised to a higher position. When the light so obtained is not sufficient for proper examination, recourse must be had to a separate apparatus, the *bull's-eye condenser*. This is a plane convex lens of strong curvature fixed to a stand giving adjustments in different directions. It is interposed between the light and the object, *with its plane side toward the object* in such a manner that the lens will concentrate the light upon its upper surface.



## ILLUMINATION WITH SUBSTAGE CONDENSER.

Up to this point the matter of illumination has been treated in its most simple form as being given with mirror only, but we must now consider the substage condenser, which is a most valuable adjunct to the microscope. While skillfull treatment of the mirror only will go far toward obtaining good results, it will not suffice except in the most simple investigations.

**Purpose of the Condenser.** The purpose of the condenser is not only as its name implies, to condense light, and thus give an amply illuminated field when the illumination is otherwise insufficient, but is more especially to illuminate the object with a cone of light having an angular aperture equal to that of the objective, which is absolutely unattainable with a mirror only, as well as to provide means for controlling the amount and character of the illumination to suit the various conditions of work.

**Abbe Condenser.** The history of the substage condenser is very unique and interesting and shows how, from having been the subject of no end of con-

demnation, which for many years it received, it is now generally accepted as a necessary adjunct to a complete outfit, should in fact be part of an equipment in which there is a medium power dry or an oil immersion objective. From single lenses, compound and achromatic lenses, the use of eyepieces and objectives as condensers and any number of devices for regulating the light, the generally accepted forms at the present time have come to be those devised by Prof. Abbe. One of them with a numerical aperture of 1.20 consists of a combination of two lenses, Fig. 49, and the other with an aperture of 1.42 of three lenses, Fig. 50. A third is made achromatic with an aperture of 1.0. It is, however, considerably more expensive.



Fig. 49.



Fig. 50.

The particularly distinguishing feature of these condensers is that they will transmit a beam of light as large as can pass within the limits of the substage ring.

The one of 1.20 N. A. is that in most common use as it meets the conditions for all except the most critical requirements.

The condensers are mounted in a variety of forms offering greater or less facility for vertical adjustment,

the amount and direction of light, the displacement of condenser when it is not used, etc.

The most simple form, largely used for instruments for laboratory and everyday work, is one which has attached to its lower side an iris diaphragm for regulating the amount and angle of light and to which is attached a swinging arm to receive blue glass for use with artificial light, or stops for dark ground or oblique illumination. A vertical screw motion gives a serviceable means of adjustment and when at its lowest limit of adjustment it may be swung out of the optical axis.

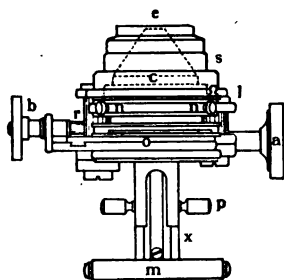

Fig. 51a. Complete Substage.  
Front view.

The most complete form is that shown in Fig. 51a, b and c, which has adjustments for obtaining every modification and character of illumination, with rack and pinion for vertical adjustment and swinging the condenser and iris diaphragm out of the way if it is not desired to use them.

The condenser should not be used on very low power objectives as it is distinctly harmful and the mirror alone provides ample illumination.

The following description of the parts of the complete substage will facilitate its use.

**The Complete Substage** consists of a vertical bar fixed to the microscope in place of the mirror bar and having an adjustable slide *x* operated by rack and pinion *a*, carrying supporting attachments for upper iris diaphragm, condenser and lower iris diaphragm respectively, and at its lower end the plane and concave mirrors *m*.

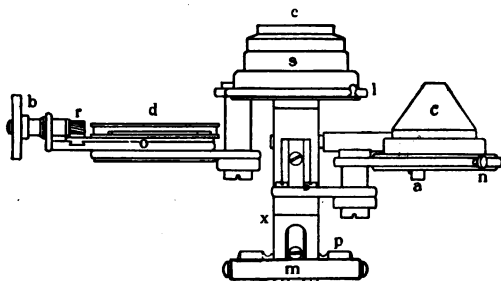
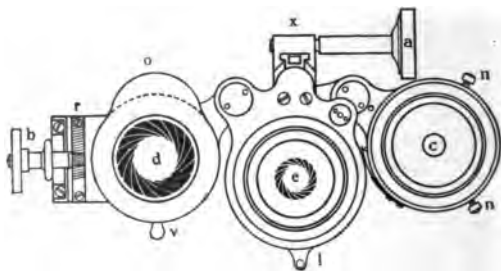

Fig. 51b. Complete Substage. Front view, with condenser and lower iris diaphragm swung out of optical axis.

**The Upper Iris Diaphragm** *e* is carried in the upper substage ring *s*. In use it is opened and closed by the lever *l* and serves to regulate the amount of light when an object is viewed without the condenser and to limit the volume of light without reducing its angle when the condenser is used with extremely transparent objects, such as unstained bacteria, moulds, etc. It is raised and lowered by the pinion *a* which moves the whole substage.

**The Condenser *c*** is carried in the lower substage ring mounted on a lateral axis by which it may be swung to the left, out of the optical axis. It has a centering adjustment operated by the milled heads *n n* by which its axis can be made to correspond with that of the instrument with the greatest facility.



**Fig. 51c. Complete Substage. Top view, with condenser and lower iris diaphragm swung out of optical axis.**

**The Lower Iris Diaphragm *d*** is mounted on the plate *o* attached to a lateral axis by which it can be swung to the right out of the path of light from the mirror. It has a lateral motion by the rack and pinion *r b* on the plate *o* and rotates on its own axis so that when oblique illumination with the condenser is desired a small aperture of the diaphragm may be brought the proper distance from the optical axis and rotated to bring it opposite to the direction from which the light

comes to the mirror or at right angles to the striae of striated structures. The diaphragm  $d$  is operated by the lever  $v$ .

*Use only plane mirror with the condenser.*

A condenser is so constructed that parallel rays of light are brought to a focus above the upper surface of its uppermost lens and in the plane of the object, Fig. 52. If the concave mirror is used the convergence of light is more rapid and the apex of the cone of light is within the condenser, Fig. 53, and its effectiveness depreciated.

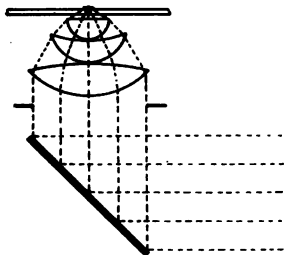

Fig. 52. Illuminating object with condenser and plane mirror.  
The right way.

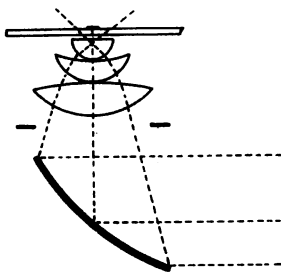

Fig. 53. Illuminating object with condenser and concave mirror.  
The wrong way.

**Centering the Condenser** is the act of bringing its optical axis coincident with the optical axis of the objective.

In the simple forms of microscopes in which the work is not critical, the condenser as sent out is

sufficiently centered by the maker for all ordinary requirements but there should be provision to center it in case of disarrangement.

In the more complete apparatus adjustment screws should be supplied. These provide a ready means of centering and when once the correct position with one objective is determined it will not require any further attention.

To verify correct centering two easy methods may be followed :

*I. Use a 2 inch objective and focus through the condenser onto the diaphragm, which is reduced to its smallest opening.*

*II. Use a 2-3 or 1 inch objective; focus upon upper surface of condenser or upon an object which should then be removed; elevate objective with coarse adjustment until a dimly defined dark spot appears in the field and with proper focusing is about 1-3 of the diameter of the field.*

Centering of the condenser does not imply that the cone of illumination is also centered and it is fully as important to secure the correct conditions in one as it is in the other.

**Centering the Illumination.** The mirror may be so adjusted that the light will be directed toward the periphery of the condenser and when lamplight is used

the light may be so placed, as to give all gradations of oblique illumination from the central to the limit of aperture, although the condenser may be centered;

*With daylight have evenly illuminated field.*

*With lamplight attach 2-3 inch objective; open diaphragm to full extent and focus upon the minute image of flame; adjust mirror so that the image will be in the center of the field.*

**To Focus Condenser.** Since the condenser is nothing more than a combination of lenses similar to those in an objective, but used in a reversed position, it has the same properties of angular aperture, focus and working distance. But, as it must work through the thickness of slide, its working distance is proportionately long. Owing to the variation in thickness of slides, its focus falls in some slides above and in others below its effective position, in relation to the object, and an adjustment is therefore necessary to make it most effective.

In all the various forms of mountings the condenser is so mounted that at the uppermost limit of adjustment its upper surface is just below the surface of the stage so that it cannot come in contact with the slide.

*With all objectives having a numerical aperture less than 1.0 the condenser may be used dry, i. e. without oil.*



In the use of the condenser with oil immersion objectives the custom prevails of using the condenser dry. It is convenient especially in changing specimens and meets the requirements of every day work. It is well to point out, however, that both the condenser and the objective lose in their efficiency when the former is used dry, and for critical work the condenser should be in immersion contact with the slide.

*To make immersion contact between condenser and the slide place a drop of oil on the top of condenser, drop the slide upon the stage, first throwing the clips to one side.*

With immersion objectives the proper focusing of the condenser becomes a matter of nice distinction to obtain best results and can only be reliably accomplished by considerable practice and experience. To obtain best position :

*Use a 2-3 objective ; focus upon the object ; adjust condenser until image of window-sash or flame is in the same plane with the object.*

**Relation of Aperture of Condenser to Objective.** In the study of Bacteria and other microorganisms the objectives used being of wide aperture, it is sought to have them stand out boldly in a bright field. This is accomplished by bringing the diaphragm to its full aperture. On all other objects, however,

too much illumination decidedly injures definition by obliterating detail.

Little experience is required to judge when the condenser has its proper opening. When correct, the image will stand out sharply defined without any appearance of fogginess and as the diaphragm aperture is reduced it will be noticeable by the decrease in the amount of light. By removing the eyepiece and looking at the back of the objective the relative aperture of the condenser to that of the objective may be easily seen, as the outlines of the diaphragm are sharply defined. In testing for this, start with the smallest aperture of the diaphragm and gradually increase its diameter. If the opening in diaphragm appears to have the same opening as the back of objective, the condenser has the same angular aperture. In the following instructions for the proper use of light from the condenser the size of opening of its diaphragm as it appears by viewing the back of the objective is called *apparent aperture*. By experience the following conditions have been found to give most satisfactory results :

*With oil immersion objectives on bacteria use the full opening of diaphragm.*

*For diatoms reduce the apparent aperture to about two-thirds opening in objective.*

*For histological and other dense objects the apparent aperture should be equal to about one-half the opening of back lens in objective.*

*With dry objectives the aperture of the condenser should always be less than that of the objective.*

**Oblique Light with Condenser.** Oblique light may be obtained by setting the mirror alone in such a position that the light reflected from it shall enter the condenser only at one side, leaving the balance of it unused. This, however, is only advisable when the condenser mounting has no other provision for obtaining oblique light. In the mountings having such provision oblique illumination may be obtained by two methods:

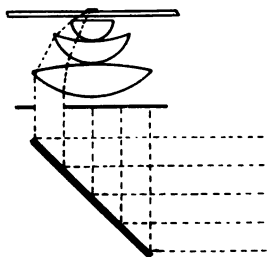

Fig. 54. Illuminating object by oblique light with condenser.

*I. Focus objective; reduce the apparent aperture to that of the rear lens of the objective, swing the plate *o*, Fig. 51a, carrying the lateral adjustment around so that the pinion button is at the front. Turn the pinion button so that the opening will move from the center to the periphery of the condenser, Fig. 54.*

*II. Proceed as above with this difference: Remove eyepiece and view the bright circle of light as it passes from the center to the periphery of the rear lens.*

When the circle of light has passed beyond the limit of aperture of the objective the field will become dark. The amount of illumination may be modified, but in a general way it may be said that the best results with oblique illumination are obtained by reducing the amount of illumination to its minimum practicable amount.

In objects with striated structure, the illuminating rays should be brought to a position at right angles to the striae, either by rotating the object to the proper position, or by swinging the diaphragm plate.

In using process II the circle of light should be bright. As it nears the edge, colors become apparent until finally at the edge of the objective the violet and red are quite pronounced. With proper disposition of the mirror the colors may be so equalized that after a little practice the illumination will be found at its best after the eyepiece is applied.

With either method lamplight will be found to give best results but care must be taken that, as the diaphragm passes toward the oblique point, the mirror is also turned so that the illumination will not be lost.

In the Abbe condensers the chromatic aberrations are quite apparent with extreme oblique illumination—more so with that of 1.40 N. A. than with 1.20 N. A. The field ceases to be equally illuminated and all the colors of the spectrum from the violet to the red are

plainly evident within the field of view. Under these conditions it is of course impossible to view large specimens without slightly shifting the mirror so as to move the lightest portions of the spectrum to different parts of the field. With small specimens the mirror should be so directed that the light or yellow portion of the spectrum is in the middle of the field.

## HOW TO DRAW OBJECTS.

To be able to make a correct drawing of the enlarged image of an object is very important and while for some lines of work the photographic camera is called into use, drawings are nevertheless largely relied upon. The apparatus requisite for this purpose is the *camera lucida* and while there is a variety of forms, all are based upon the principle of causing the image of the object to appear projected upon the paper, where it may be drawn.

The image of the object, the paper and the pencil point are viewed at the same time and, with proper regulation of light, are equally distinct. The microscope image seems to be projected upon the paper and it is only necessary to draw the outlines and fill out details to obtain an exact picture of it.

The most simple form is that shown in Fig. 55. With this the microscope must be inclined to a horizontal position or nearly so and the camera lucida attached to the eyepiece. The pencil of light from the



Fig. 55.

microscope is reflected by the thin film of glass into the eye and the image is apparently projected beyond the glass upon the paper where the pencil point may trace out its details.

The best form and that which has nearly superceded all others which have made pretense to giving good results is the *Abbe camera lucida*, Fig. 56.

While in the original construction it gave superior results it has been gradually improved, so that in its



Fig. 56.

complete state it leaves nothing to be desired. Its price is necessarily high but it is also offered in simplified form to meet more modest demands and will with proper use do very good work although not as good nor with equal facility as the more complete.

The optical construction, Fig. 57, is the same in all forms. Two 1-4 inch rectangular prisms of which one has a silvered diagonal surface with a central opening of one half the diameter of the pupil of the eye, are cemented

together at their diagonal surfaces, thus forming a cube. At one side of the cube about 3 inches from it is a mirror set at an angle of about 45 degrees. The optical parts are mounted in various degrees of mechanical completeness to be clamped to the tube in such a manner that the glass cube is situated above the eye lens.

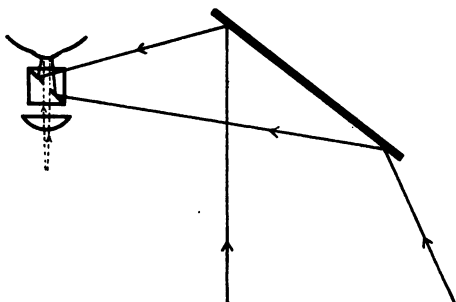

Fig. 57. Optical construction of Abbe camera lucida.

A very simple form is one with a small fixed mirror near the tube and arranged to swing out so that the eyepiece is unobstructed.

Another form has large mirror which is adjustable in its inclination to the table and distance from the eyepiece. This form is provided with dark glass discs at the side and below the prism to control the amount of illumination from the object and the paper. The best form gives full control of the mirror, has rotating discs



carrying a series of dark glasses of different shades, has centering arrangement to bring the opening of the cube into the optical axis and swings out so that the object can be viewed without disturbing the camera lucida.

To obtain satisfactory results with any camera lucida several fundamental rules must be observed :

*Use sharp pencil point. If spectacles are necessary or read they must be used with the camera lucida to see the pencil point.*

*The light in the field of view and from the drawing surface should be of about the same intensity.*

*The drawing surface should be at right angles to the axis of the projected image, otherwise there will be an elongated picture and distortion at one end.*

*Draw the outline of the image and indicate the details of structure in light lines and complete the drawing without the camera lucida by reference to the microscope.*

**Illumination.** The relative illumination of the field in the eyepiece and drawing paper varies with the magnifying power and distance of paper from the eyepiece. The control of the illumination in the better class of camera lucidas provided with glass shades is comparatively easy, but in the simple forms several expedients must be resorted to.

With low power objectives the light in the field in the eyepiece is stronger than that from the paper. It may be modified

*by using plane mirror,  
by covering the mirror with tissue paper,  
by using a small opening of the substage diaphragm.*

With the higher powers the conditions are reversed and the field of the paper appears brighter than that in the eyepiece.

*In this case reduce the light on the paper by using a tissue paper or opaque screen.*

*Use substage condenser and modify light with the iris diaphragm.*

**Arrangement of Drawing Surface.** As has been stated this should be at right angles to the axis of the projected image. In all camera lucidas the reflecting mirror is quite close to the tube of the microscope which is supposed to be in upright position and if set so that the axis of the cone of projected rays is vertical, there will be no distortion, or in other words the field of view will be perfectly circular. It will be found, however, that the stage and base of the microscope will project within this circle and so prevent obtaining a complete drawing of the object. The mirror of the camera lucida must therefore be so tilted as to throw the cone of rays farther away from the

microscope which would form an elongated or distorted image and to correct this the drawing surface must be sufficiently tilted to bring it at right angles to the axial ray. An easy method to determine whether the surface is at a right angle is to mark the outlines of the field of view on the paper at the right and left and at the front and back extremes and measure the distance. The surface should be so tilted that the distance in both directions is the same.

If the microscope is tilted another complication arises inasmuch as the drawing surface must be tilted with it.

**Field and Magnification.** The size of the drawing of an object depends upon

*the initial magnification of the microscope,  
the distance of the drawing from the eyepiece.*

Drawings should be made with such objectives and eyepieces as would be used to examine structure. As the distance of the drawing surface from the eyepiece is increased the image becomes larger. The size of drawing must therefore be regulated by varying the height of the drawing surface.

**To Use the Simple Camera Lucida.** *Focus the objective upon the object; incline microscope to the horizontal position, raise microscope by underlaying with blocks or books, readjust mirror and attach camera*

*lucida, place paper upon the table or board, view through camera lucida for correct position and fasten with drawing tacks; modify light so that image and pencil point are equally distinct.*

**Use of the Abbe Camera Lucida.** Care must be observed in attaching this to the microscope tube. The opening in the silvered surface of the glass cube must be so placed that it will be coincident with the focal point and axis of the eyepiece. If too high or low the field will be reduced or one side of the field will be cut off.

*Focus upon object; attach camera lucida and adjust so that field is round and not cut off.*

*Place drawing board with paper attached at right hand side of microscope; look into camera lucida and adjust reflecting mirror; place paper in proper position and tilt board to proper inclination; place pencil upon the paper and regulate light from both fields until image and pencil are equally distinct.*

**To Measure the Amount of Enlargement.** This is accomplished by means of a stage micrometer (which as has already been stated consists of a very fine scale which is ruled upon the glass slide) after the drawing is made.

*Remove the object and replace with stage micrometer. Place so that one of the lines coincides with the outline*

*of the image at one side and indicate each line of the micrometer on the drawing until the outline at the opposite side is reached. The computation is made by dividing the diameter of the drawing by the value of a division of micrometer multiplied by the number of divisions which are projected on the drawing. Thus if the ruling on the micrometer is 0.01 mm. and 10 divisions cover the outline of the drawing, while the actual measurement of the drawing is 30.0 mm. the formula would be  $30 \div (1-100 \times 10) = 300$ .*

If a standard of 10 inches is maintained in all drawings and the amount of magnification with certain objectives and eyepieces be previously determined by means of the micrometer, a standard is established for each and further measurement will not be required. If, however, variations from this standard distance are made, the actual magnification should always be determined.

The magnification is sensitive to slight variations in the distance. The standard distance of 10 inches is determined by measuring from the optical axis of the microscope to the axis of the mirror of the camera lucida and from this to the drawing surface.

**Drawing Table.** It will be noticed that great stress has been laid upon the fact of keeping the drawing surface at right angles to the axis of the projecting cone of rays and that the drawing board must be tilted

to accomplish this. In order to maintain a standard distance of 10 inches or to vary this distance to meet requirements the drawing surface must be raised or lowered. This can only be done by blocks or books and the tilting by underlaying or by cutting a block with properly inclined surface, which, however, is fixed in height. All of these methods are crude and cumbersome and easily liable to derangement. An excellent substitute is offered in the drawing table, Fig. 58,

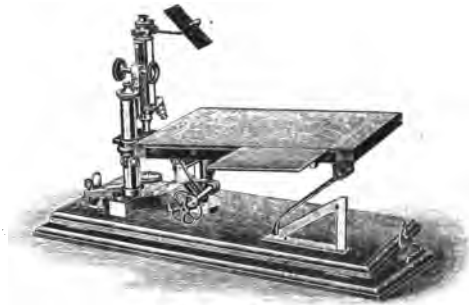

Fig. 58.

which while simple in construction and inexpensive is very serviceable. Upon its base, the upper part of which is hinged, the microscope is clamped. The drawing board is fastened to a hinged attachment which is adjustable for height. The pawl at the right provides the necessary amount of inclination and the extent of this is indicated by a quadrant at the hinge. An arm rest is provided which may be moved along the front.

**To Determine Magnifying Power.** While the magnifying power may be known from tables accompanying the microscope, these are only approximate, as there is more or less variation in eyepieces and objectives and furthermore the microscope may be used under different conditions from those under which the original determinations were made.

To determine magnifying power three requisites are necessary :

*A camera lucida.*

*A stage micrometer ruled in divisions of inches or millimeters.*

*A pocket or foot rule in inches or millimeters,* according to the stage micrometer which is used.

The stage micrometer is a glass slip having a very fine scale ruled upon it. The lines are often so fine as to be nearly invisible except under the microscope.

*Place the stage micrometer with divisions of 0.01 mm. upon the stage and focus. Attach the camera lucida, place the microscope in exactly the same position as for drawing, maintaining the standard distance of 10 inches from optical axis to drawing paper; mark the spaces of the micrometer as projected upon the paper and determine how many of the divisions of the rule are contained within one or more spaces on the paper. If the values are in millimeters and it should be found that 25.0 mm. on the rule are contained in one space*

on the paper, the magnification would be 2500. If 18.6 on the rule are contained within three spaces on the paper, the magnification would be 620 times.

**To Measure the Size of an Object.** One of the most valuable possibilities of the microscope is to be able to accurately measure the actual size of a minute object. Computations may be made in inches or millimeters by figuring 25.4 mm. equal to 1 inch. It may be done by several methods, either of the following being generally employed :

The first of these gives satisfactory results on coarser objects and wherever the most accurate results are not required, although it is somewhat inconvenient. The requisites are :

*A camera lucida.*

*A stage micrometer.*

The object is placed upon the stage and after focusing, the camera lucida is attached and the instrument set up exactly as for drawing. On the drawing paper the outlines of object, or those portions which are to be measured, are marked. Without in the least disturbing any of the conditions of tube length or distance from the paper, remove the object and replace it by the stage micrometer, focusing only with the fine adjustment and, it may be added, there should be very little variation in thickness between the two slides. Move



the micrometer so that one of its lines shall exactly coincide with one end of the drawing on the paper and then measure off how many spaces are covered by the object. Thus if 0.001 inch is the value of the micrometer spaces and the object covers one space, its size will be 0.001 inch, or covering seven spaces will be 0.007 inch.

A variation of the distance of the camera lucida from the paper, or a change of power in eyepiece or objective does not vary the results so long as object and micrometer are used under exactly the same conditions.

The second method is with the eyepiece micrometer or micrometer eyepiece. The eyepiece micrometer consists of a circular disc of glass of suitable size to just fit inside the tube of the eyepiece, resting upon the diaphragm at the focus of the eye lens, scale side up, or mounted in an oblong holder to be slipped into a slot in the eyepiece mounting just above the diaphragm. In case the lines on the eyepiece micrometer do not show plainly, adjust the eye lens until they do. The micrometer eyepiece, Fig. 45, in which the eyepiece and micrometer form a complete apparatus and a lateral adjustment of the scale across the field is given by a screw, is much more convenient.

In either of these forms the ruled lines appear to lie directly on the image of the object, but while we

have on the one hand the actual value of the micrometer we have on the other only the image of the object. The value of the eyepiece micrometer in the value of the stage micrometer must be first determined. While the optician can do this, it should be done by the manipulator on account of the varying conditions of tube length, power of objective, etc. A stage micrometer ruled in the same values as the eyepiece micrometer is necessary.

*Focus the eye lens on the eyepiece micrometer and the objective on the stage micrometer, being careful to bring the first line of the former coincident with a line of the latter, using care to see that they are parallel. As the lines of the stage micrometer will appear to have a certain*

*amount of thickness, make the first line of the eyepiece micrometer correspond with one edge of a line on the other. Now read off how many of the lines are contained in one space of the stage micrometer and note this. We will assume that there are eight divisions.*

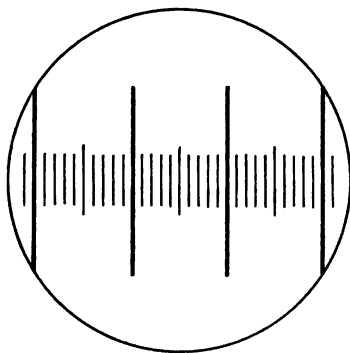

The eyepiece micrometer compared with the stage micrometer.

Replace the stage micrometer by the object to be measured and bring one edge of the object coincident with the first line of the eyepiece micrometer, being careful to leave all the conditions unchanged. Note how many divisions are required to cover the object and divide by the figure first obtained with the stage micrometer.

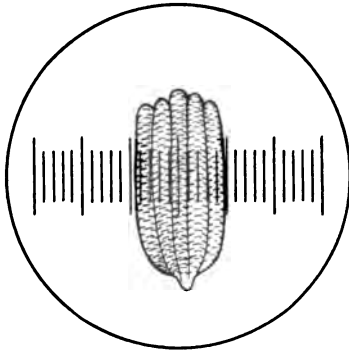

Measuring an object with the eyepiece micrometer.

Thus if an object covers forty spaces of the eyepiece micrometer its real size will be  $(40 \div 8) \times 0.01 \text{ mm.} = 0.05 \text{ mm.}$

If measurements are made under exactly the same conditions of tube length, with same objectives, it will be unnecessary to repeat the operation with eyepiece and stage micrometer, as the ratio remains constant and maybe marked on a card for reference.

The most efficient apparatus, however, for obtaining accurate results is the *filar* or *screw micrometer*, Fig. 59. This consists of a metal case to the upper surface of

which is fitted an adjustable Ramsden eyepiece. Within is a frame carrying one or several delicate spider lines, which are moved across the space to be measured by



Fig. 59.

an accurate screw of either 0.5 mm. or 1-50 inch pitch, which has at its end a graduated disc divided in 100 or more spaces, thus giving a definite value for each

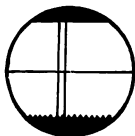

Field of Filar Micrometer.

space. An adapter is also provided for attaching to the tube of the microscope.

## TO SELECT A MICROSCOPE.

When one has concluded to obtain a microscope, a suitable selection is a matter of considerable importance to him. The varieties are innumerable, prices without end, all sorts of claims made for them.

The variety of special lines of investigation involves nearly as great a variety of requirements. The amount of money to be expended; what shall be the stand; what the objectives; shall the entire outfit be purchased at one time or little by little; are all questions of paramount importance which the writer does not expect to solve, but hopes to give sufficient information so that a more intelligent selection may be made than might probably be done otherwise.

If one has a friend or teacher, who is generally accepted as an authority, it will be well to consult him or her and obtain suggestions as to the most suitable selection for the intended work, and such advice will always be gladly given. Or, if advice is asked of a reputable manufacturer, the writer is convinced that it will be honestly and disinterestedly given.

When means will permit, the outfit for immediate requirements should be obtained complete and as Prof. Gage says, "the best that can be afforded should be obtained," and further, "even when all the optical parts cannot be obtained in the beginning it is wise to secure a stand upon which they may all be used when they are finally secured." The writer agrees entirely with this advice. Even though the stand be plain, it should be good, with the necessary adjustments and capable of receiving and fully utilizing such further accessories as may be obtained later on.

**Stand.** While one's sense of the aesthetic may be a factor it is mainly the practical utility which must govern the decision. Whether large or small must largely be determined by the future use to which it is to be put. One rule may apply to all, however, and that is, that the instrument shall be so balanced that it will be absolutely steady during manipulation in the upright or inclined position. In general the low Continental stand is preferred as it permits of resting the arms upon the table while moving the object and a more comfortable position while looking through the tube whether the instrument be upright or inclined.

**Tube Length.** In the matter of tube length the optical results are the same in both, so that tube length must be considered only in so far as it affects the

height of the instrument. The short tube length of 160.0 mm. is at the present time in general use.

**Base.** The base is an important feature and while it should not be over heavy, should insure steadiness by the proper form and disposition of metal ; it should not rest on more than three points, with the rear one fairly distant from the pillar.

**The Joint for Inclination.** This, without question, is an advantage and while it is an inexpensive addition it will add considerably to the comfort of working and should invariably be present, if pecuniary considerations do not absolutely prohibit it.

**Coarse Adjustment.** Almost all reliable instruments are provided with both fine and coarse adjustments. The choice of the latter lies between the sliding tube and the rack and pinion. The former has only the advantage of economy and is a decided disadvantage in the hands of students who almost invariably injure objectives and preparations with it. Further than this, it is almost impossible for the maker to center the nose-piece to the tube, so that a change of objective usually throws an object out of the field and requires that it be looked for anew with each change. With the rack and pinion the nose-piece has an unvarying relation to the tube and is not liable to this difficulty and offers a steady and agreeable adjustment. The

advantages of the rack and pinion seem to be generally appreciated in this country and there are few instruments sold and used without it. Dr. Stokes speaks of the sliding tube adjustment as follows:

“This is a very inconvenient and undesirable arrangement. It is awkward, since the friction is often so great that the whole stand will move out of position before the body will budge, and frequently, more frequently than not, even when the foot is heavy enough to keep the instrument firmly on the table, both hands are needed to manipulate the body. It is dangerous too, since under certain circumstances the body has the obnoxious habit of suddenly slipping farther than the microscopist intends, stopping only when it crashes against the slide, where it usually grinds and crunches cover glass and objective with apparently fiendish glee. A stand without a coarse adjustment by rack and pinion is a good stand to be permanently left with the optician. No fine microscopical work can be done with an instrument whose body slides through a friction collar. That arrangement may be cheap, but it is also a torment and a peril.”

**Rack and Pinion.** This should be absolutely smooth with no back-lash or lost motion throughout its entire length, which can be determined by holding the main tube and working the pinion buttons very slightly but quickly back and forth. It should be perfectly



fitted in its bearings, so that there will not be the least side motion and this should be tested under the magnifying power of an objective. There should be no sensation of the individual teeth coming in contact. It is safe to assume that if the rack and pinion shows either of the above defects, the instrument is faulty in other directions as well.

**Fine Adjustment.** Nothing in the microscope will cause more aggravation than a faulty fine adjustment. It should work with absolute smoothness and with no side play in the screw. The body should respond promptly, when moving the milled head rapidly forward and backward and should not cause any swaying of the image during observation. The micrometer screw should be back of the pinion, not at the front of the tube nor under the stage.

**Metal.** Whether an instrument shall be of japanned iron or lacquered brass is probably largely determined by the amount of money to be expended. So far as the intrinsic suitability of the metals is concerned there is no difference. Brass, however, offers the maker a better opportunity for displaying his mechanical skill and while it is no doubt true that many highly finished instruments are of poor workmanship in their working parts, it is also a fact that a well made instrument is always nicely finished.

**Size and Weight.** The size of instrument is worthy of consideration. If an instrument is to remain stationary in a practitioner's office or laboratory, it may be large without being cumbersome. If, however, it is intended to be carried about it should be of the smaller and more contracted pattern.

**Working Space Below Stage.** Another important consideration is the space between the stage and base, or table. While it is advisable to have the stage low on account of the convenience in manipulating a slide, there should still be sufficient space for the convenient attachment of substage accessories. In this respect the American instruments are superior as they are built for the better accommodation of accessories.

**Stage.** A variety of stages is offered on instruments of similar construction. The plain, flat stage, while preferred by some, offers no advantages over the ordinary round one, unless specially made for examining specimens on larger slides than the standard 3 by 1 inch. Those stages in which the upper surface is covered with vulcanite offer many advantages. The spring clips are usually of similar construction, although varying in detail and curves. Properly constructed clips should have such elasticity as to allow specimens to be brought under them without resistance and keep them properly in place, without too much pressure and consequent friction.

**The Mechanical Stage**, while an absolute necessity in petrographical and other work where a systematic search, as for bacilli or in blood counting, over the entire surface of object is required, will also be found a most useful accessory. The obstacle of considerable cost which formerly prevailed is now removed and good mechanical stages may be obtained at a very reasonable cost. They are supplied in two forms :

*Fixed mechanical stage*, in which the mechanical movement is an integral part of the stage.

*Attachable mechanical stage*, which can be attached to the Continental stands having plain stages. This has advantages, since it may be removed, leaving the stage plate free, but it cannot be revolved. Either form involves the most delicate work and while the parts are necessarily small should be built with a view to strength and durability. They should work with the utmost *precision* and *smoothness* and with *absolutely no lost motion*.

**Revolving Stage.** While this is also a great convenience in all work, it is a necessity in some directions, and when provided with centering screws may be used to some extent as a mechanical stage with only a limited movement, however. It should work freely with the rolling motion of one finger, without any side play and without throwing the object out of the plane of focus during revolution.

**Substage.** This is an absolute necessity in a modern microscope, except perhaps for students' use in primary work. It should have a vertical adjustment and preferably with rack and pinion. If possible select the complete substage attachment.

**Substage Condenser.** If means will permit, purchase this, as it is in all work most convenient and in some, bacteriology, etc., absolutely necessary. The Abbe condenser is the cheapest form giving good results and one with numerical aperture of 1.20 is sufficient in all cases unless oil immersion objectives of the greatest aperture are used.

**Objectives and Eyepieces.** It is hoped that the information given of the various qualities in an objective will aid to make a suitable selection of the optical parts. Since the stands have been classified as of long and short standard tube lengths, the first quality to look for is, after the stand has been selected, the suitability of objective and eyepiece to it and to the work. A variety of powers is obtained by a suitable combination of eyepieces and objectives and while a considerable increase in power can be obtained by short focus eyepieces this is not advantageous.

**Eyepiece.** Select the Huyghenian eyepiece and no higher power than 3-4 inch. In catalogues many outfits are made up of one eyepiece and two objectives, but this is only for economy; it is always advisable to

select two eyepieces, preferably the 2 inch and 1 inch and insist that they be parfocal, as this will be found extremely convenient and will not disturb the optical standard length. If for any work 1-2 inch or higher powers are desired, the solid eyepiece may be recommended. With the apochromatic objectives use the compensating eyepieces only. Every eyepiece should be marked with its equivalent focus.

**Objectives.** For all ordinary student and professional work, not involving bacteriological investigations, the 3-4 inch 0.22 N. A., and 1-5 inch 0.62 N. A. for long tube; and 2-3 inch 0.24 N. A., and 1-6 inch 0.85 N. A. or 1-8 inch 0.93 N. A., for short tube have generally been accepted as best suited.

Bacteriological investigations absolutely require an oil immersion objective in which the 1-12 inch of 1.32 N. A. is generally employed.

Botanical work necessitates a 2 inch or 3 inch in addition to the regular outfit.

For urinary work and blood counting where a considerable working distance is an absolute necessity the 1-5 or 1-6 inch of reduced aperture and long working distance are recommended.

**Objectives of Wide Aperture.** It will be noted that objectives of the lowest price and lowest in the scale of efficiency have been recommended as ample for ordinary use, but it is well to bear in mind or study the advantage which is obtained by objectives

of larger angular aperture. These advantages are absolute and unquestionable, but whether commensurate with the additional pecuniary outlay must be left mostly to the judgment of the purchaser. That he may be somewhat guided, we may say that the selection of higher or highest grade objectives is not by any means exceptional, but general, and would undoubtedly be more common but for the barrier of expense.

In these days of competition, prices alone are too often made the inducement without any reference to quality. Be distrustful of all such objectives and if contemplating their purchase, always reserve the right of having them examined by an expert. Have a distrust especially of all "nameless" objectives. It is safe to assume that if the maker cannot attach his name he is doubtful of their quality.

It is sometimes found that dealers offer the same objectives of different quality at different prices. Too great care cannot be observed in such cases, as the very fact of the admission of a difference in quality indicates that they are made by an unreliable maker. This mode of offering objectives was in vogue many years ago when the principles of optics and the facilities for making were limited and when a higher price was asked for those which might be termed a happy combination. There is no excuse, however, at the present day, for anything of this kind, because every conscientious optician has his standard for every objective.

In purchasing a microscope a beginner may be easily misled by the enticing appearance of an object, which may be due not so much to the instrument as to the object itself and if the optical parts are inferior, it will require but a short experience to become convinced of it—usually as soon as a comparison can be made with reliable work. The investment in one of these objectives is not only a source of disappointment, but usually proves to be a pecuniary loss, as it is generally followed by a fresh outlay in responsible work. It is of ordinary occurrence that such objectives have been sent to the writer's firm with the request to examine them and rectify the faults; but an examination almost invariably proves that the cost of doing so is considerably greater than that of a new objective of the same power and it would not even then be equal to the latter.

**Accessories.** We have already stated in the body of this book which kinds of accessories are considered useful. Some of them are absolutely necessary in some special lines of work, in which case, however, the student is generally conversant with the requirements and may make a suitable selection, but for all general purposes some accessories are necessities where others are only conveniences and we append a list of such which, unless prohibited by necessity, should accompany each outfit.

Abbe.substage condenser, preferably the complete substage attachment giving all adjustments.

Double, triple or quadruple nose-piece according to the number of objectives accompanying the microscope.

Abbe camera lucida.

Revolving or attachable mechanical stage.

Eyepiece micrometer and stage micrometer.

Mounted objects, Proboscis of Blow-fly and *P. angulatum*, dry.

Pocket magnifier, preferably Aplanatic or Hastings triplet.

Cover glass gauge.

Flat-wick oil lamp.

Dissecting stand or dissecting microscope.

Besides these there are other requirements such as slides, covers, mounting media, forceps, etc., the necessity of which, however, will be suggested by teachers or can be determined from books devoted to this purpose. There are other articles which in some directions are necessities, but are general conveniences, among which may be mentioned :

Adjustable drawing table.

Polariscope.

Bull's Eye Condenser.

Photomicrographic camera.

Live box or compressor.

Turn table.

Revolving microscopical table.

Cabinet for objects.



## CARE OF A MICROSCOPE.

Besides acquiring the ability to properly use an instrument with its accessories, it is important to know how to keep it in the best working condition. It may be said without reserve that an instrument properly made at the outset and judiciously used should hardly show any signs of wear either in appearance or in its working parts, even after the most protracted use ; and further than this, every good instrument should have a provision for taking up lost motion, if there is a likelihood that this may occur in any of the parts.

Especial care should be given to the optical parts, in fact such care that they will remain in as good condition as when first received, after any amount of use. Accidental injury may occur, but is quite unlikely if a systematic manner of working is followed, if a special receptacle for each part is provided.

Do not allow any person except your teacher to manipulate your microscope or accessories. One person may be expert in the manipulation of one instrument and still find it difficult to work with another. The fine adjustment particularly causes the

greatest difficulty, as in some instruments the movement of the fine adjustment is in a direction opposite to that of the micrometer screw, and thus the objective as well as the object is endangered.

If the microscope is to be carried any distance it should be done in its case.

Avoid exposure of the microscope to direct sunlight and extreme or sudden changes in temperature. If by chance the microscope should have become very cold, as during transportation in winter, allow it to warm gradually.

**Care of the Stand.** *Keep free from dust is one of the first rules to be observed.* When not in use place the microscope in its case or cover with a bell jar or close mesh cloth such as cotton flannel or velvet which should reach to the table. If the case will not receive the entire outfit, remove the double or triple nose-piece, if these form part of it, and place objectives in their cases. If dust settles on any part of the instrument remove it first with a camel's hair brush and then wipe carefully with a chamois skin, wiping with the grain of the finish of the metal and not across it, as in the latter case it is likely to cause scratches.

*When handling the stand, grasp it by the pillar or stage.* While the arm is the most convenient part it is at the same time the most dangerous to the fine adjustment.

*Avoid sudden jars*, such as placing upon the table or into the case with force.

*Remove any Canada balsam or cedar oil* which may adhere to any part of the stand with a cloth moistened with benzole and wipe dry with chamois.

*Use no alcohol* on any part of the instrument as it will remove the lacquer. As the latter is for the purpose of preventing oxydization of the metals, it is important to observe this rule.

*To use the draw-tube impart the spiral motion.*

*To lubricate* any of the parts, use a slight quantity of soft tallow or good clock oil, or paraffine oil.

*If the pinion works loose* from the jar incident to transportation or long use, which sometimes occurs to such an extent that the body will not remain in position, increase its tension by tightening the screws on pinion cover.

*Occasionally withdraw the tube from the arm, wipe clean and lubricate both slides.* This is highly important as the slides being constantly exposed become dusty and the lubricant is inclined to gum.

Apply a small quantity of soft tallow or good clock or paraffine oil to a cloth, wipe well over the surfaces and remove the superfluous amount with a dry cloth or Japanese paper. If the lubricant becomes gummy, remove by wiping with a small quantity of benzine or benzole applied to cambric.

*Do not apply oil or grease to the rack or pinion* as this will act as a dirt catcher and wear out the teeth at the points of contact.

*In inclining the stand* always grasp it by the arm and never by the tube, as in the latter case it may loosen the slide or tear off some of the parts.

*In using a screw driver* grind its two large surfaces so that they are parallel and not wedge-shaped, so it will exactly fit in the slot of the screw-head. Turn the screw with a slow steady motion pressing the screw-driver firmly into the slot. No screw-head will ever be injured if these points are observed.

*When repairs or alterations are necessary,* always have these made by the manufacturers who can, from a system of duplicated parts, do it not only cheapest, but best.

**Joint for Inclination.** If the joint should become loose so as to prevent the arm being set at any angle of inclination, it should be tightened by drawing up the nut at one or the other side. If the nut has screw slot use a properly prepared screw driver, but if two holes a suitable key should be obtained from the maker. In high grade instruments the axle is generally tapering, and to determine which nut is to be drawn up can only be done by trial.

**Care of the Coarse Adjustment.** Special care should be given to keep the coarse adjustment free from dust as its effect is particularly pernicious. The slides and rack and pinion are necessarily exposed and the lubricant is apt to catch dust and also to gum. The tube should be occasionally withdrawn from the arm and the slides carefully wiped with a cloth moistened with benzole. Lubricate by applying a small quantity of soft tallow or paraffine oil to a cloth and wiping well over the surfaces, removing the superfluous amount with a dry cloth. The teeth of neither rack nor pinion should ever be lubricated. An occasional cleaning of the teeth with an old tooth brush is advisable.

It is advisable occasionally to lubricate the pinion shank on both sides of the arm with a very minute quantity of paraffine oil.

*If the pinion works loose* from jar incident to transportation or long use, which sometimes occurs to such an extent that the body will not remain in position, increase the friction upon it by tightening the screws on the pinion cover.

**Fine Adjustment.** In a general way it may be said that if the fine adjustment ceases to work satisfactorily the instrument had better be returned to the maker, as it involves the most delicate working and few people are conversant with its construction. There

is very seldom any occasion for this, however, if used with reasonable care.

*If the fine adjustment does not respond* to the turning of the micrometer screw, or if it comes to a stop, it indicates that the adjustment screw has come to the limit of its motion at either end. It should by no means be forced; it should at all times be kept at a medium point.

*The micrometer screw* should never be removed unless after long use it works with a pronounced gritty feeling. In this case unscrew from its bearing, wipe clean with a cloth moistened with benzole, and after wiping dry apply good tallow, being careful to start the threads properly. If they are not properly started much mischief may be done. In some instruments the threads are left handed. In removing the screw observe whether there is a small steel pin in a recess in it, and if so be careful that this is in proper position when returned or else the fine adjustment will be inoperative.

**Screw-Driver.** Ordinary screw-drivers are not fit for use on the microscope. A properly made screw-driver should be ground on its two large surfaces so that they are parallel and not wedge shaped, so that it will exactly fit in the slot of the screw head. In using, turn the screw with a slow, steady motion, pressing the screw-driver slowly into the slot. No screw head will ever be injured or marred if these points are observed.

**Care of Objectives and Eyepieces.** Every outfit should be provided with a camel's hair brush and a well washed piece of linen. On account of its fine texture chamois skin is desirable, but only after it has been repeatedly washed. No dust should be permitted to settle upon nor should the fingers come in contact with any of the surfaces. Occasional cleaning is desirable even when they (*o* and *e p*) are not used, as a film settles upon the outer as well as the inner surfaces of the eyepiece and the rear surface of the objective, and creates a cloudiness in the image.

When not in use objectives and eyepieces should be kept in their receptacles. If objectives are left attached to the microscope either singly or on revolving nose-pieces, leave the eyepiece in the tube so that no dust can enter and settle upon the rear lens of the objective.

Objectives especially should be kept where they are not subject to extreme and sudden changes of temperature as the expansion and contraction may cause the cement between the lenses to crack. Also avoid direct sunlight, as the cement may soften sufficiently to ooze out.

**Eyepiece.** *Visible defects in the field* are always traceable to impurities in the eyepiece, not in the objective, and are easily recognized by revolving it. Indistinctness in the image or loss of light may be due

to soiled or coated surfaces in either eyepiece or objective.

*Dust if on either the eye-lens or field-lens* is apparent as dark, indistinct spots.

*To clean the surfaces, breath upon them* and, giving a revolving motion to the eyepiece, wipe with well washed linen and finally blow upon the surface, or use camel's hair brush to remove particles of lint.

*At regular periods unscrew the eye-lens and field-lens* and clean the inner surfaces.

**Objective.** *This should be used with the utmost care. The systems should never be separated,* even if they can be unscrewed, as they are liable to become decentered and dust may enter.

*Avoid all violent contact* of the front lens with the cover glass. The oil immersion objectives are particularly sensitive and easily ruined.

*Screw into the nose-piece and unscrew* by grasping the knurled edge and keeping in line with the tube.

*Occasionally examine the rear surface of the objective* with magnifier and if dust be present remove with camel's hair brush.

*Clean an immersion objective immediately* after it has been used by removing the fluid with moist cloth and wiping clean with dry cloth or lens paper.

While cleaning give the objective a revolving motion.



*If the immersion oil should have become thick, or any substance adheres to the surface, which cannot be removed by wiping, apply a small amount of benzine to a cloth and wipe carefully but quickly, so that the fluid will not affect the setting of the lens. Wipe clean with dry cloth.*

*Do not apply alcohol to objectives under any condition.*

---

If any part of the microscope cannot be brought to a satisfactory working condition by the foregoing instructions, or any part is injured by accident it should invariably be sent to the maker or to a well known manufacturer of microscopes.

## INDEX.

Abbe Camera Lucida,	168—173, 193
Optical Construction of,	168
Abbe Condenser,	154
Abbe Test Plate,	142
Aberration, Chromatic,	10, 85
Correction of,	12
Spherical,	9, 12, 88, 138
Accessories to Microscope,	192
Achromatic Combination or Lens,	13
Adjustable Objectives,	64, 93, 143
Adjustments, Coarse and Fine,	32, 45, 48
Care of,	198
Closed and Open,	93, 143
Amplification,	100
Angle,	70, 72
Angular Aperture,	70, 80, 101'
How to Measure,	80
Anterior System of Objective,	66
Apertometer,	82
Aperture,	72, 162
Numerical,	77
Of Condenser,	162
Aplanatic Lens,	13
Aplanatic Triplet,	16, 23
Hastings',	16, 23
Apochromatic Objectives,	102
Apparent Aperture,	163
Areas Magnification,	24
Arm of Microscope,	29
Astigmatism,	131
Attachable Mechanical Stage,	41, 188
Axis, Optical,	34
Principal,	5

<b>Barnes Dissecting Microscope,</b>	20
<b>Base of Microscope,</b>	29, 51, 184
<b>Binocular Eyepiece,</b>	110
<b>Binocular Microscope,</b>	44
<b>Blood Counting,</b>	40, 190
<b>Bodies or Tubes,</b>	44
<b>Body of Microscope,</b>	29
<b>Bruecke Lens,</b>	17
<b>Bull's Eye Condenser,</b>	153, 193
<b>Burning Point,</b>	7
<b>Cabinet for Objects,</b>	193
<b>Camera Lucida,</b>	167—177
<b>Camera Lucida, Abbe,</b>	168—173
<b>Drawing Table for,</b>	175
<b>Field and Magnification with,</b>	172
<b>How to Use,</b>	172, 173
<b>Illumination with,</b>	170
<b>Measuring Magnification with,</b>	176
<b>Measuring Size of Object with,</b>	177
<b>Optical Construction of,</b>	169
<b>Simple Form,</b>	167, 172
<b>Cap Diaphragms,</b>	54, 131
<b>Care of Microscope,</b>	194
<b>Cedar Oil,</b>	61, 75, 146
<b>Centering Screws,</b>	33, 39
<b>Centering the Condenser,</b>	159
<b>Centering the Illumination,</b>	160
<b>Chromatic Aberration,</b>	10, 85
<b>Correction of,</b>	86
<b>To Judge,</b>	86
<b>Classification of Microscopes,</b>	34
<b>Clips,</b>	33
<b>Closed Adjustment,</b>	93, 143
<b>Coarse Adjustment,</b>	32, 45, 184
<b>Care of,</b>	198
<b>Coddington Lens,</b>	15

Collar,	31
Collar Correction,	143
Collective or Field Lens,	58, 107
Compensating Eyepiece,	103, 111
Complete Substage,	156—158
Compound Microscope,	1, 27
Concave Lenses,	4, 6
Concave Mirror,	121, 152
Focal Point of,	122
Use with Condenser,	159
Condenser,	122, 154—166
Aperture of,	162
Bull's Eye,	153
Centering of,	159
Focusing of,	161
Illumination with,	164
Oblique Light with,	164
Purpose of,	154
Substage,	156
Use with Immersion Objectives,	162
Continental Type Eyepiece,	107
Continental Type Microscope,	35
Convex Lenses,	4, 5
Focal Length of,	5, 6
Correct Position at the Microscope,	115
Corrected Lens,	13
Cover Glass,	34, 74
Abbe Test Plate for Measuring,	142
Correction for,	88
Influence upon Objective,	140
Influence upon Angular Aperture,	74
Influence upon Spherical Aberration,	88
Sizes of,	141
Standard,	91
Thickness to Use,	93
Cover Glass Gauge,	93, 193

<b>Crown Glass in Achromatic Combination,</b>	13
<b>Defects in Eyepieces and Objectives,</b>	112
<b>Diameters Magnification,</b>	24
<b>Diaphragm,</b>	10, 33, 129
<b>Cap,</b>	54
<b>Eyepiece,</b>	107
<b>Iris,</b>	54, 157, 158
<b>Revolving,</b>	53
<b>Substage,</b>	53, 129, 157, 158
<b>Use of,</b>	129, 163
<b>Diatoms as Test Objects,</b>	133
<b>Dispersion of Light by Prism,</b>	11
<b>Dissecting Microscopes,</b>	18—21, 193
<b>How to Use,</b>	21
<b>Double Nose-piece,</b>	43, 118
<b>To Focus with,</b>	127
<b>Double System of Lenses,</b>	66
<b>Doublet Magnifier,</b>	15
<b>Draw-Tube,</b>	31, 49
<b>To Operate,</b>	50, 114
<b>Drawing Objects with Camera Lucida,</b>	167
<b>Drawing Table,</b>	174, 175
<b>Dry Adjustable Objectives,</b>	143
<b>Dry Objectives,</b>	60, 75
<b>English Type Eyepiece,</b>	107
<b>Erecting Eyepiece,</b>	110
<b>Equivalent Focus,</b>	62
<b>Excelsior Dissecting Microscope,</b>	20
<b>Eye, Which to Use,</b>	21, 131
<b>Eye-lens,</b>	58, 107
<b>Eyepiece or Ocular,</b>	31, 55, 107—110, 189
<b>Binocular,</b>	110
<b>Care of,</b>	200
<b>Compensating,</b>	103, 111
<b>Continental Type,</b>	107

Eyepiece or Ocular, Defects in,	112
English Type,	107
Erecting,	110
How to Attach,	116
Huyghenian,	107
Index,	111
Kellner,	109
Micrometer,	109, 110, 178, 181
Negative,	107
Orthoscopic,	109
Parfocal,	106
Periscopic,	109
Projection,	109, 112
Ramsden,	109
Rating of,	104
Searcher,	111
Selection of,	189
Solid,	108
Eyepiece Micrometer,	179, 193
Eyepoint,	132, 105, 106
Field of View,	16, 17, 95, 101, 104
Field, Flatness of,	95
Field-lens,	58, 107
Filar Micrometer,	180
Finding the Object,	118
Fine Adjustment,	32, 48, 186
Care of,	198
Focusing with,	128
Fixed Mechanical Stage,	41, 188
Flatness of Field,	95
Flint Glass in Achromatic Combination,	13
Focal Length,	5
To Determine,	6
Focal Point,	5
Of Mirror,	53, 122
Focus, Equivalent,	62

Focus, Principal,	5
Virtual and Real,	6
Focusing the Condenser,	161
Focusing the Objective,	124
Focusing with Fine Adjustment,	128
Glass, Crown and Flint,	13
Jena,	57
Glass Stage,	39
Graduated Head,	48
Graduated Stage,	38
Hastings' Aplanatic Triplet,	16
Head, Micrometer Screw,	48
High Power Objectives,	63, 99
How to Focus,	125
Test Objects for,	133
Holders, Stands and Dissecting Microscopes,	18
Homogeneous Immersion Fluid,	61
Homogeneous Immersion Objectives,	60, 75, 146
Huyghenian Eyepieces,	107
Illuminating the Object,	23, 120, 124, 159, 164
Illuminating Objectives,	64
Illuminating Opaque Objects,	152
Illumination with Substage Condenser,	154
Image, Magnified,	27
Real and Virtual,	8, 59, 105, 106
Immersion Fluid,	61
Immersion Objectives,	60, 75, 146
Applying Oil to,	146
Test Plate with,	147
Index,	48
Index Eyepiece,	111
Iris Diaphragm,	54, 129, 157, 158
Jena Glass,	57
Joint for Inclination,	52, 184, 197
Kellner Eyepiece,	10

Lens Holders or Stands,	18
Lens Systems,	66
Lenses, How Made,	67
Magnifying,	14—24
Optical Properties of,	1
Simple,	4
Stopped down,	10
Linear Magnification,	24
Linen Tester,	19
Lister's Method for Measuring Angular Aperture,	81
Low Power Objectives,	62, 99
How to Focus,	125
Text Objects for	1ç2
Lower Iris Diaphragm,	158
Magnifier, Tripod,	18
Magnifiers,	14—24, 193
Caution in Purchasing,	16, 24
How to Use,	21
Magnification with Camera Lucida,	172, 173
Magnifying Power.	7, 21, 24, 60, 84, 99
To Determine,	25, 176
Measuring the Size of an Object,	177
Mechanical Stage,	40, 120, 188, 193
Medium Power Objectives,	62, 99, 136
Test Objects for,	133
Meniscus Lenses,	4
Metal for Microscope,	186
Micrometer, Eyepiece,	178
Filar,	180
Stage,	177
Micrometer Eyepiece,	109, 110, 178, 181
Micrometer Screw Adjustment,	32, 48, 199
Microscope, Binocular,	44
Care of,	194
Caution in Purchasing,	24
Classification of,	34



<b>Microscope, Compound,</b>	1, 27, 59
<b>Continental Type,</b>	35, 183
<b>Correct Position at,</b>	115
<b>Dissecting,</b>	18—21
<b>How to Set up,</b>	114
<b>How to Work with,</b>	114
<b>Jackson Model,</b>	34
<b>Material of,</b>	28, 186
<b>Monocular,</b>	44
<b>Parts of,</b>	29
<b>Purpose of,</b>	1
<b>Ross Model,</b>	34
<b>Selection of,</b>	182
<b>Simple,</b>	1, 14
<b>Size and Weight of,</b>	187
<b>Microscopical Table, Revolving,</b>	193
<b>Middle System of Objective,</b>	66
<b>Milled Heads,</b>	32
<b>Mirror,</b>	33, 52, 120, 157
<b>Focal Point of,</b>	53
<b>Use with Condenser,</b>	159
<b>Mirror Bar,</b>	33, 52
<b>Negative Eyepiece,</b>	107
<b>Nose-piece,</b>	31, 42, 193
<b>Revolving,</b>	43
<b>Numerical Aperture,</b>	77
<b>How to Compute,</b>	78
<b>How to Measure,</b>	80
<b>Of Condenser,</b>	155
<b>Object,</b>	34, 132
<b>Finding under the Microscope,</b>	118
<b>How to Draw,</b>	167
<b>Measuring Size of,</b>	177
<b>Opaque,</b>	151
<b>To Illuminate,</b>	120
<b>Test,</b>	132, 192

Object, What to use as,	132
Objective,	31, 55, 60, 99, 189, 190
Adjustable,	64, 143
Angular Aperture of,	70
Apochromatic,	102
Care of,	69, 200, 201
Caution in Choosing,	190
Color Correction in,	86
Construction of,	67
Defects in,	112
How to Focus,	124
How to Attach,	117
Immersion,	60, 75, 146
Illuminating,	64
Influence of Cover Glass on,	93
Photographic Microscope,	64
Powers of,	62, 99
Projection,	65
Quality of,	70
Rating of,	62
Searcher,	126
Special,	64
Systems of,	65
Variable,	64, 143
Wide Aperture,	190
Oblique Light with Condenser,	164
Ocular,	31, 55, 104, 200
Oil Immersion Objectives,	60, 75, 99, 146
Opaque Objects,	151
Open Adjustment,	143, 145
Opening or Aperture,	73
Optical Axis,	34
Optical Glass,	57, 67
Optical Properties of Lenses,	1
Orthoscopic Eyepiece,	109
Over-Correction of Objectives,	86

Over-Correction of Objectives, To Judge,	87
<b>Parfocal Eyepieces,</b>	106
Penetration	94
Periscopic Eyepiece,	109
Photographic Microscope Objectives	64
Pillar,	29
Pinion,	32, 198
Plane Mirror,	52, 121
Use with Condenser,	159
Plankton Work,	40
Pleurosigma Angulatum, 100, 133, 134, 136, 139, 144, 148, 193	
Pocket Magnifiers,	14—24, 193
Positive Eyepiece,	107
Posterior System of Objective,	66
Powers of Objectives,	62, 99, 101
Primary Colors,	11
Principal Axis,	5
Principal Focus,	5
Prism, Dispersion of Light by,	11
Refraction of Light by,	2
Projection Eyepiece,	109, 112
Projection Objectives,	65
Quadruple Nose-piece,	43, 118
Quadruple System of Lenses,	66
Rack and Pinion, Substage,	157, 158
Rack and Pinion Coarse Adjustment,	32, 46, 183
Rack and Pinion Mechanical Stage,	41
Radius of Curvature,	5
Ramsden Eyepiece,	109
Rating of Eyepieces,	104
Rating of Objectives,	62
Reading Glass,	17
Real Focus,	6
Real Image,	8, 58, 105, 106
Refraction,	2

Resolving Power,	82, 101
Test Objects for Determining,	132
Revolving Diaphragm,	53, 131
Revolving Nose-piece,	43
To Focus with,	127
Revolving Stage,	38, 188
Screw Driver,	199
Screw Micrometer,	180
Searcher Eyepiece,	111
Searcher Objective,	126
Secondary Spectrum,	85, 102
Simple and Compound Microscopes,	1, 14, 27
Simple Lenses,	4
Magnifying Power of,	25
Single System of Lenses,	66
Size and Weight of Microscope,	187
Slide or Slip,	34
Slide Carrier,	39
Sliding Tube Adjustment,	45, 184
To operate,	128
Slow Motion,	48
Society Screw,	31
Solid Eyepiece,	108
Special Objectives,	64
Spectrum,	11, 85, 102
Spherical Aberration,	9, 88, 96
Influence of Cover Glass on,	88
To Judge,	138
Spring Clips,	33, 187
Stage,	18, 32, 187
Construction of,	37
Glass,	39
Mechanical,	40, 120, 188
Revolving,	38, 188
Working Space Below,	187
Stage Micrometer,	176, 177, 179, 193

<b>Stand,</b>	18, 28
<b>Care of,</b>	195
<b>Selection of,</b>	183
<b>Striae,</b>	112
<b>Substage,</b>	33, 156
<b>Complete,</b>	157
<b>Substage Condenser, Illumination with,</b>	154
<b>Substage Diaphragm,</b>	53
<b>Use of,</b>	129
<b>Systems of Objectives,</b>	65, 99
<b>Table, Drawing,</b>	175, 193.
<b>Test Objects,</b>	132
<b>Test Plate,</b>	133, 147
<b>Judging Spherical Aberration with,</b>	142
<b>Use with Immersion Objectives,</b>	147
<b>Triple Nose-piece,</b>	43, 118
<b>Triple System of Lenses,</b>	66
<b>Triplet Magnifiers,</b>	16
<b>Tripod Magnifier,</b>	18
<b>Tube Length,</b>	35, 36, 61, 183
<b>Tubes or Bodies,</b>	44
<b>Turn Table,</b>	193
<b>Under-Correction of Objectives,</b>	86
<b>To Judge,</b>	87
<b>Universal or Society Screw,</b>	31
<b>Upper Iris Diaphragm,</b>	157
<b>Variable Objectives,</b>	64
<b>Virtual Focus,</b>	6
<b>Virtual Image,</b>	8, 58, 105, 106
<b>Water Immersion Objectives,</b>	75
<b>Working Distance,</b>	17, 96
<b>To Measure,</b>	98
<b>Working Space below Stage,</b>	187





COUNTWAY LIBRARY



HC 2Mw9 8

S.J.1901.5

Manipulation of the microscope, 1901

Countway Library

AGS7420



3 2044 045 011 905



3.J.1901.5

Manipulation of the microscope,1901

Countway Library

AGB7420



3 2044 045 011 905